



Industrial Hose

Insta-Lock™ Couplings
Technical & Chemical Guide

Insta-Lock™ Type A Fitting

Male Adapter x Female NPT Thread



Application

Type A fitting is commonly threaded onto a pipe, threaded hose end or manifold system, which is connected and disconnected on a regular basis. Insta-Lock fittings are designed for liquids only. Consult the chemical resistance guide for specific chemical recommendations.

Materials

Aluminum, 316# Stainless Steel and Brass

Branding

Example: Continental ContiTech A200SS

Order Codes

Aluminum: 650-825

Stainless Steel: 650-841

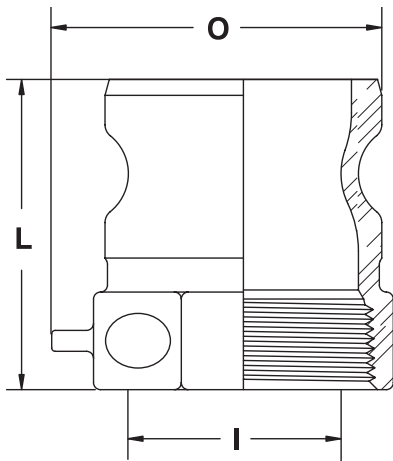

See next page for detailed specifications.

Insta-Lock™ Type A Fitting

Male Adapter x Female NPT Thread

Size	Aluminum	SAP Reference	Stainless Steel	SAP Reference	Brass	SAP Reference
0.50"	A050AL	20195274	A050SS	20195328	A050BR	20494938
0.75"	A075AL	20195276	A075SS	20195329	A075BR	20494939
1.00"	A100AL	20135788	A100SS	20135857	A100BR	20457073
	A100AL BSPT	20443563	A100SS BSPT	20443577		
1.25"	A125AL	20135789	A125SS	20135858	A125BR	20494970
	A125AL BSPT	20443571	A125SS BSPT	20443578		
1.50"	A150AL	20135790	A150SS	20135895	A150BR	20494971
	A150AL BSPT	20443572	A150SS BSPT	20443579		
2.00"	A200AL	20135791	A200SS	20135896	A200BR	20457074
	A200AL BSPT	20443573	A200SS BSPT	20443580		
2.50"	A250AL	20135792	A250SS	20135897	A250BR	20494972
	A250AL BSPT	20443574	A250SS BSPT	20443581		
3.00"	A300AL	20135794	A300SS	20135898	A300BR	20457075
	A300AL BSPT	20443575	A300SS BSPT	20443582		
4.00"	A400AL	20135795	A400SS	20135899	A400BR	20457076
	A400AL BSPT	20443576	A400SS BSPT	20443583		
5.00"	A500AL	20195277	A500SS	20195341	A500BR	20494973
6.00"	A600AL	20195278	A600SS	20195342	A600BR	20494974

Insta-Lock Type A Fitting

Size	Distance Chain Lug Extends from Body	Maximum Width Across Adapter (O)	Overall Length (L)	Minimum ID (I)
0.50"	0.375"	1.500"	1.656"	0.5000"
0.75"	0.375"	1.688"	1.656"	0.7810"
1.00"	0.375"	1.804"	2.163"	0.8750"
1.25"	0.375"	2.237"	2.437"	1.0625"
1.50"	0.375"	2.368"	2.531"	1.3750"
2.00"	0.375"	2.909"	2.781"	1.7500"
2.50"	0.375"	3.585"	3.093"	2.1870"
3.00"	0.375"	4.009"	3.281"	2.8120"
4.00"	0.375"	5.257"	3.528"	3.7500"
5.00"	0.375"	6.438"	3.813"	4.6880"
6.00"	N/A	7.688"	3.656"	5.7500"

Note: Continental ContiTech Insta-Lock fittings are never to be used in steam or compressed air service.

Continental ContiTech Insta-Lock cam arms are designed exclusively for Insta-Lock fittings.

Insta-Lock™ Type B Fitting

Female Coupler x Male NPT Thread



Application

Type B fitting is normally threaded into a pipe or manifold that joins to a rubber hose assembly, which is connected and disconnected regularly. Insta-Lock fittings are designed for liquids only. Consult the chemical resistance guide for specific chemical recommendations.

Materials

Aluminum, 316# Stainless Steel and Brass

Branding

Example: Continental ContiTech B200SS

Order Codes

Aluminum: 650-826

Stainless Steel: 650-842

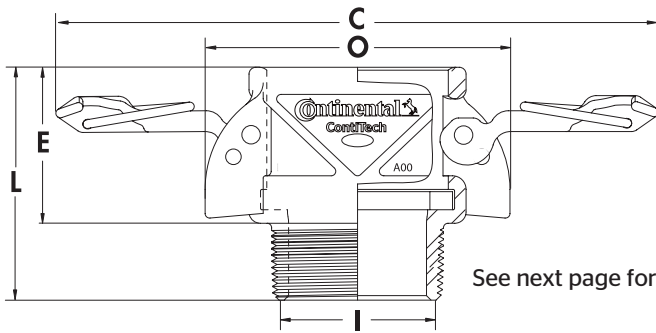

See next page for detailed specifications.

Insta-Lock™ Type B Fitting

Female Coupler x Male NPT Thread

Size	Aluminum	SAP Reference	Stainless Steel	SAP Reference	Brass	SAP Reference
0.50"	B050AL	20195279	B050SS	20195343	B050BR	20457075
0.75"	B075AL	20195290	B075SS	20195344	B075BR	20494975
1.00"	B100AL	20139546	B100SS	20139492	B100BR	20494976
	B100AL BSPT	20443584	B100SS BSPT	20443591		
1.25"	B125AL	20139547	B125SS	20139493	B125BR	20494977
	B125AL BSPT	20443585	B125SS BSPT	20443592		
1.50"	B150AL	20139548	B150SS	20139494	B150BR	20494978
	B150AL BSPT	20443586	B150SS BSPT	20443593		
2.00"	B200AL	20139549	B200SS	20139495	B200BR	20494979
	B200AL BSPT	20443587	B200SS BSPT	20443594		
2.50"	B250AL	20139580	B250SS	20139496	B250BR	20494980
	B250AL BSPT	20443588	B250SS BSPT	20443595		
3.00"	B300AL	20139581	B300SS	20139497	B300BR	20450759
	B300AL BSPT	20443589	B300SS BSPT	20443596		
4.00"	B400AL	20139582	B400SS	20139498	B400BR	20450690
	B400AL BSPT	20443590	B400SS BSPT	20443597		
5.00"	B500AL	20195291	B500SS	20195345	B500BR	20494981
6.00"	B600AL	20195292	B600SS	20195347	B600BR	20494982

Insta-Lock Type B Fitting

Size	Max. Width with Cam Arms Closed (O)	Overall Length (L)	Exposed Length (E)	Minimum ID (I)	Max. Width with Cam Arms Extended (C)
0.50"	2.47"	1.906"	1.188"	0.4690"	4.900"
0.75"	2.78"	2.031"	1.313"	0.6880"	5.178"
1.00"	2.92"	2.500"	1.625"	0.8750"	5.367"
1.25"	3.51"	2.937"	2.000"	1.0625"	7.669"
1.50"	3.83"	2.937"	2.000"	1.3750"	7.967"
2.00"	4.21"	3.218"	2.156"	1.7500"	8.340"
2.50"	4.72"	3.718"	2.250"	2.1870"	8.837"
3.00"	5.68"	4.000"	2.468"	2.8120"	10.435"
4.00"	6.78"	4.218"	2.593"	3.7500"	11.538"
5.00"	7.81"	4.406"	2.625"	4.6880"	12.534"
6.00"	9.34"	4.750"	2.844"	5.7500"	16.058"

Note: Continental ContiTech Insta-Lock fittings are never to be used in steam or compressed air service.

Continental ContiTech Insta-Lock cam arms are designed exclusively for Insta-Lock fittings.

Insta-Lock™ Type C Fitting

Female Coupler x Hose Shank

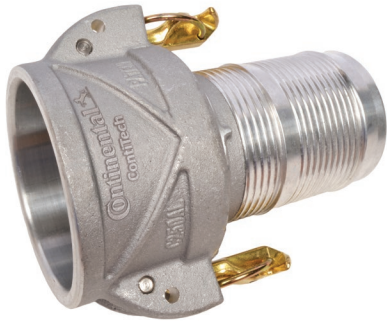

Application

Type C fitting can be attached to a rubber hose with the use of interlocking ferrules, crimp sleeves or bands. Insta-Lock fittings are designed for liquids only. Consult the chemical resistance guide for specific chemical recommendations.

Materials

Aluminum, 316# Stainless Steel and Brass

Branding

Example: Continental ContiTech C200SS

Order Codes

Aluminum: 650-827

Stainless Steel: 650-843

Brass: 650-835

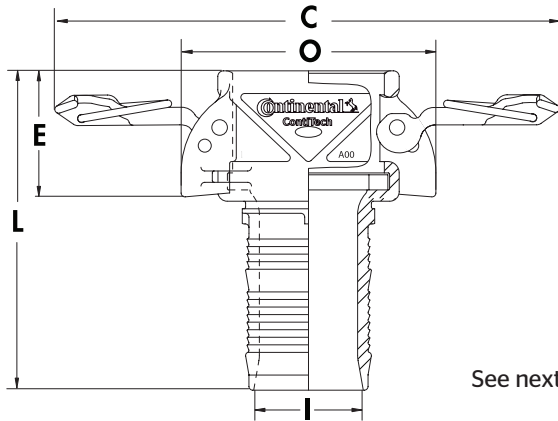

See next page for detailed specifications.

Insta-Lock™ Type C Fitting

Female Coupler x Hose Shank

Size	Aluminum	SAP Reference	Stainless Steel	SAP Reference	Brass	SAP Reference
0.50"	C050AL	20195293	C050SS	20195348	C050BR	20450781
0.75"	C075AL	20195294	C075SS	20195349	C075BR	20450780
1.00"	C100AL	20139583	C100SS	20139475	C100BR	20218518
1.25"	C125AL	20139584	C125SS	20139476	C125BR	20450778
1.50"	C150AL	20139585	C150SS	20139477	C150BR	20218519
2.00"	C200AL	20139586	C200SS	20139478	C200BR	20218730
2.50"	C250AL	20139587	C250SS	20139491	C250BR	20264867
3.00"	C300AL	20139588	C300SS	20139479	C300BR	20218731
4.00"	C400AL	20139589	C400SS	20139490	C400BR	20218732
5.00"	C500AL	20195295	C500SS	20195360	C500BR	20450754
6.00"	C600AL	20195296	C600SS	20195362	C600BR	20450657

Insta-Lock Type C Fitting

Size	Max. Width with Cam Arms Closed (O)	Overall Length (L)	Exposed Length (E)	Minimum ID (I)	Max. Width with Cam Arms Extended (C)
0.50"	2.47"	3.063"	0.821"	0.260"	4.902"
0.75"	2.78"	3.656"	1.313"	0.490"	5.178"
1.00"	2.92"	4.250"	1.975"	0.718"	5.367"
1.25"	3.51"	4.625"	2.350"	0.906"	7.669"
1.50"	3.83"	4.750"	2.370"	1.156"	7.967"
2.00"	4.21"	5.281"	2.531"	1.625"	8.340"
2.50"	4.72"	5.750"	2.625"	2.093"	8.837"
3.00"	5.68"	6.840"	2.849"	2.560"	10.435"
4.00"	6.78"	7.218"	2.994"	3.468"	11.538"
5.00"	7.81"	7.563"	2.625"	4.469"	12.534"
6.00"	9.34"	8.969"	2.844"	5.469"	16.058"

Note: Continental ContiTech Insta-Lock fittings are never to be used in steam or compressed air service. Continental ContiTech Insta-Lock cam arms are designed exclusively for Insta-Lock fittings.

Insta-Lock™ Type D Fitting

Female Coupler x Female NPT Thread



Application

Type D fitting is commonly threaded onto a pipe, threaded hose end or manifold assembly, which is connected and disconnected on a regular basis. Insta-Lock fittings are designed for liquids only. Consult the chemical resistance guide for specific chemical recommendations.

Materials

Aluminum, 316# Stainless Steel and Brass

Branding

Example: Continental ContiTech D200SS

Order Codes

Aluminum: 650-828

Stainless Steel: 650-844

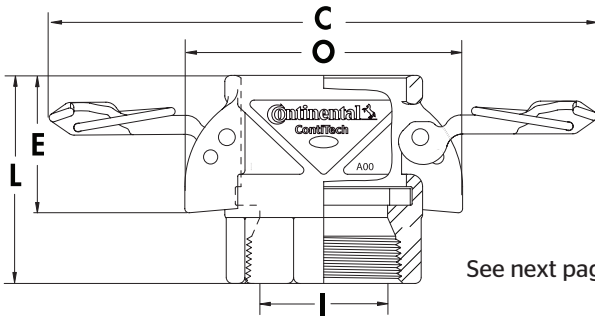

See next page for detailed specifications.

Insta-Lock™ Type D Fitting

Female Coupler x Female NPT Thread

Size	Aluminum	SAP Reference	Stainless Steel	SAP Reference	Brass	SAP Reference
0.50"	D050AL	20195297	D050SS	20195363	D050BR	20494983
0.75"	D075AL	20195298	D075SS	20195364	D075BR	20457076
1.00"	D100AL	20139451	D100SS	20139458	D100BR	20457077
	D100AL BSPT	20443598	D100SS BSPT	20443605		
1.25"	D125AL	20139452	D125SS	20139459	D125BR	20494985
	D125AL BSPT	20443599	D125SS BSPT	20443606		
1.50"	D150AL	20139453	D150SS	20139470	D150BR	20457078
	D150AL BSPT	20443600	D150SS BSPT	20443607		
2.00"	D200AL	20139454	D200SS	20139471	D200BR	20457079
	D200AL BSPT	20443601	D200SS BSPT	20443608		
2.50"	D250AL	20139455	D250SS	20139472	D250BR	20494984
	D250AL BSPT	20443602	D250SS BSPT	20443609		
3.00"	D300AL	20139456	D300SS	20139473	D300BR	20450656
	D300AL BSPT	20443603	D300SS BSPT	20443610		
4.00"	D400AL	20139457	D400SS	20139474	D400BR	20450659
	D400AL BSPT	20443604	D400SS BSPT	20443611		
5.00"	D500AL	20195299	D500SS	20195365	D500BR	20494986
6.00"	D600AL	20195310	D600SS	20195366	D600BR	20494987

Insta-Lock Type D Fitting

Size	Max. Width with Cam Arms Closed (O)	Overall Length (L)	Exposed Length (E)	Minimum ID (I)	Max. Width with Cam Arms Extended (C)
0.50"	2.47"	1.813"	0.821"	0.656"	4.886"
0.75"	2.78"	2.063"	0.971"	0.813"	5.178"
1.00"	2.92"	2.375"	1.975"	1.000"	5.367"
1.25"	3.51"	2.687"	2.350"	1.300"	7.669"
1.50"	3.83"	2.843"	2.370"	1.560"	7.967"
2.00"	4.21"	3.156"	2.531"	1.937"	8.340"
2.50"	4.72"	3.437"	2.625"	2.312"	8.837"
3.00"	5.68"	3.718"	2.849"	2.937"	10.435"
4.00"	6.78"	4.030"	2.994"	3.750"	11.538"
5.00"	7.81"	4.313"	2.612"	4.688"	12.534"
6.00"	9.34"	4.531"	2.814"	5.750"	16.060"

Note: Continental ContiTech Insta-Lock fittings are never to be used in steam or compressed air service.

Continental ContiTech Insta-Lock cam arms are designed exclusively for Insta-Lock fittings.

Insta-Lock™ Type E Fitting

Male Adapter x Hose Shank



Application

Type E fitting can be attached to a rubber hose with the use of interlocking ferrules, crimp sleeve and bands. Insta-Lock fittings are designed for liquids only. Consult the chemical resistance guide for specific chemical recommendations.

Materials

Aluminum, 316# Stainless Steel and Brass

Branding

Example: Continental ContiTech E200SS

Order Codes

Aluminum: 650-829

Stainless Steel: 650-845

Brass: 650-837

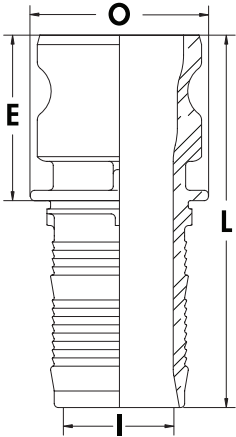

See next page for detailed specifications.

Insta-Lock™ Type E Fitting

Male Adapter X Hose Shank

Size	Aluminum	SAP Reference	Stainless Steel	SAP Reference	Brass	SAP Reference
0.50"	E050AL	20195311	E050SS	20195367	E050BR	20450785
0.75"	E075AL	20195312	E075SS	20195368	E075BR	20450783
1.00"	E100AL	20135782	E100SS	20135850	E100BR	20218733
1.25"	E125AL	20135783	E125SS	20135851	E125BR	20450779
1.50"	E150AL	20135784	E150SS	20135852	E150BR	20218734
2.00"	E200AL	20135785	E200SS	20135853	E200BR	20218735
2.50"	E250AL	20135786	E250SS	20135854	E250BR	20264866
3.00"	E300AL	20135787	E300SS	20135855	E300BR	20218736
4.00"	E400AL	20135793	E400SS	20135856	E400BR	20218737
5.00"	E500AL	20195313	E500SS	20195369	E500BR	20450755
6.00"	E600AL	20195314	E600SS	20195370	E600BR	20450658

Insta-Lock Type E Fitting

Size	Maximum OD (O)	Overall Length (L)	Exposed Length (E)	Minimum ID (I)
0.50"	1.188"	3.500"	1.625"	0.260"
0.75"	1.262"	3.969"	1.625"	0.490"
1.00"	1.625"	4.569"	1.944"	0.718"
1.25"	2.000"	4.812"	2.187"	0.906"
1.50"	2.312"	5.000"	2.250"	1.156"
2.00"	2.687"	5.625"	2.500"	1.625"
2.50"	3.062"	6.187"	2.687"	2.093"
3.00"	3.781"	7.125"	2.750"	2.562"
4.00"	4.875"	7.434"	2.809"	3.468"
5.00"	6.563"	7.844"	2.906"	4.469"
6.00"	7.125"	9.188"	3.063"	5.469"

Note: Continental ContiTech Insta-Lock fittings are never to be used in steam or compressed air service. Continental ContiTech Insta-Lock cam arms are designed exclusively for Insta-Lock fittings.

Insta-Lock™ Type F Fitting

Male Adapter x Male NPT Thread



Application

Type F fitting is normally threaded into pipe or manifold connections and mated with Part C, Part B or Part D. Used in applications that require frequent connections. Insta-Lock fittings are designed for liquids only. Consult the chemical resistance guide for specific chemical recommendations.

Materials

Aluminum, 316# Stainless Steel and Brass

Branding

Example: Continental ContiTech D200SS

Order Codes

Aluminum: 650-830

Stainless Steel: 650-846

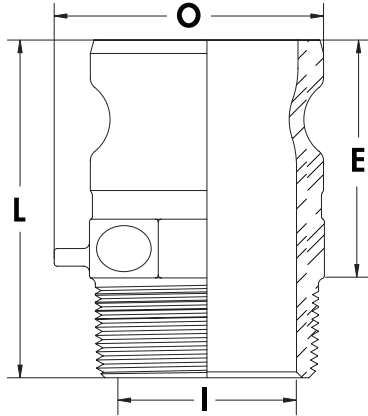

See next page for detailed specifications.

Insta-Lock™ Type F Fitting

Male Adapter x Male NPT Thread

Size	Aluminum	SAP Reference	Stainless Steel	SAP Reference	Brass	SAP Reference
0.50"	F050AL	20195315	F050SS	20195371	F050BR	20450786
0.75"	F075AL	20195316	F075SS	20195372	F075BR	20450784
1.00"	F100AL	20135775	F100SS	20135843	F100BR	20457131
	F100AL BSPT	20443612	F100SS BSPT	20443619		
1.25"	F125AL	20135776	F125SS	20135844	F125BR	20494989
	F125AL BSPT	20443613	F125SS BSPT	20443620		
1.50"	F150AL	20135777	F150SS	20135845	F150BR	20494990
	F150AL BSPT	20443614	F150SS BSPT	20443621		
2.00"	F200AL	20135778	F200SS	20135846	F200BR	20494988
	F200AL BSPT	20443615	F200SS BSPT	20443622		
2.50"	F250AL	20135779	F250SS	20135847	F250BR	20494991
	F250AL BSPT	20443616	F250SS BSPT	20443623		
3.00"	F300AL	20135780	F300SS	20135848	F300BR	20450776
	F300AL BSPT	20443617	F300SS BSPT	20443624		
4.00"	F400AL	20135781	F400SS	20135849	F400BR	20450649
	F400AL BSPT	20443618	F400SS BSPT	20443625		
5.00"	F500AL	20195317	F500SS	20195373	F500BR	20494992
6.00"	F600AL	20195318	F600SS	20195374	F600BR	20494993

Insta-Lock Type F Fitting

Size	Distance Chain Lug Extends from Body	Maximum Width Across Adapter (O)	Overall Length (L)	Exposed Length (E)	Minimum ID (I)
0.50"	0.375"	1.500"	2.250"	1.531"	0.469"
0.75"	0.375"	1.688"	2.375"	1.656"	0.688"
1.00"	0.375"	1.730"	2.819"	2.038"	0.875"
1.25"	0.375"	2.130"	3.156"	2.279"	1.187"
1.50"	0.375"	2.300"	3.222"	2.347"	1.437"
2.00"	0.375"	2.909"	3.593"	2.596"	1.750"
2.50"	0.375"	3.281"	4.218"	2.812"	2.187"
3.00"	0.375"	3.844"	4.343"	2.875"	2.812"
4.00"	0.375"	4.994"	4.746"	3.184"	3.734"
5.00"	0.375"	6.188"	4.906"	3.125"	4.688"
6.00"	N/A	7.500"	5.219"	3.313"	5.750"

Note: Continental ContiTech Insta-Lock fittings are never to be used in steam or compressed air service. Continental ContiTech Insta-Lock cam arms are designed exclusively for Insta-Lock fittings.

Insta-Lock™ Dust Cap



Application

Dust Cap is used to seal the pipe system and hose assemblies during non-use or transfer of assembly. Mating parts are Part A, Part E and Part F.

Materials

Aluminum, 316# Stainless Steel and Brass standard Nitrile gasket

Branding

Example: Continental ContiTech DC200SS

Order Codes

Aluminum: 650-831

Stainless Steel: 650-847

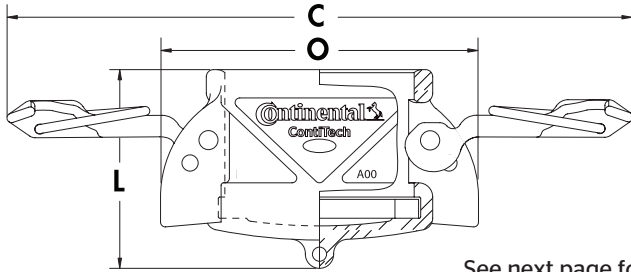

See next page for detailed specifications.

Insta-Lock™ Dust Cap

Size	Aluminum	SAP Reference	Stainless Steel	SAP Reference	Brass	SAP Reference
0.50"	DC050AL	20195319	DC050SS	20195375	DC050BR	20495001
0.75"	DC075AL	20195320	DC075SS	20195376	DC075BR	20494997
1.00"	DC100AL	20139368	DC100SS	20139444	DC100BR	20494994
1.25"	DC125AL	20139369	DC125SS	20139445	DC125BR	20494998
1.50"	DC150AL	20139440	DC150SS	20139446	DC150BR	20494995
2.00"	DC200AL	20139441	DC200SS	20139447	DC200BR	20450771
2.50"	DC250AL	20139442	DC250SS	20139448	DC250BR	20494996
3.00"	DC300AL	20139443	DC300SS	20139449	DC300BR	20450775
4.00"	DC400AL	20139600	DC400SS	20139450	DC400BR	20450757
5.00"	DC500AL	20195321	DC500SS	20195377	DC500BR	20494999
6.00"	DC600AL	20195322	DC600SS	20195378	DC600BR	20495000

Insta-Lock Dust Cap Fitting

Size	Distance Chain Lug Extends from Body	Max. Width wth Cam Arms Closed (O)	Overall Length (L)	OD with Cam Arms Extended (C)
0.50"	0.375"	2.47"	1.625"	4.886"
0.75"	0.375"	2.78"	1.656"	5.178"
1.00"	0.375"	2.92"	2.086"	5.367"
1.25"	0.375"	3.51"	2.360"	7.669"
1.50"	0.375"	3.83"	2.400"	7.967"
2.00"	0.375"	4.21"	2.633"	8.340"
2.50"	0.375"	4.72"	2.786"	8.837"
3.00"	0.375"	5.68"	2.957"	10.435"
4.00"	0.375"	6.78"	3.134"	11.538"
5.00"	0.375"	7.81"	3.219"	12.560"
6.00"	0.375"	9.34"	3.500"	16.060"

Note: Continental ContiTech Insta-Lock fittings are never to be used in steam or compressed air service. Continental ContiTech Insta-Lock cam arms are designed exclusively for Insta-Lock fittings.

Warning: Dust Caps and Dust Plugs are not to be used in pressure applications.

Insta-Lock™ Dust Plug



Application

Dust plug is used to seal the pipe system and hose assemblies during non-use or transfer of assembly. Mating parts are Part C, Part B and Part D.

Materials

Aluminum, 316# Stainless Steel and Brass

Branding

Example: Continental ContiTech DP200SS

Order Codes

Aluminum: 650-832

Stainless Steel: 650-848

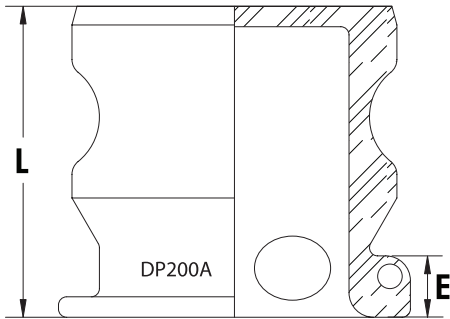

See next page for detailed specifications.

Insta-Lock™ Dust Plug

Size	Aluminum	SAP Reference	Stainless Steel	SAP Reference	Brass	SAP Reference
0.50"	DP050AL	20195323	DP050SS	20195379	DP050BR	20495002
0.75"	DP075AL	20195325	DP075SS	20195380	DP075BR	20525443
1.00"	DP100AL	20135758	DP100SS	20135696	DP100BR	20495003
1.25"	DP125AL	20135759	DP125SS	20135697	DP125BR	20495004
1.50"	DP150AL	20135770	DP150SS	20135698	DP150BR	20450782
2.00"	DP200AL	20135771	DP200SS	20135699	DP200BR	20450777
2.50"	DP250AL	20135772	DP250SS	20135840	DP250BR	20450774
3.00"	DP300AL	20135773	DP300SS	20135841	DP300BR	20450770
4.00"	DP400AL	20135774	DP400SS	20135842	DP400BR	20450772
5.00"	DP500AL	20195326	DP500SS	20195381	DP500BR	20495005
6.00"	DP600AL	20195327	DP600SS	20195382	DP600BR	20495006

Insta-Lock Dust Plug Fitting

Size	Overall Length (L)	Exposed Length (E)
0.50"	1.531"	0.500"
0.75"	1.563"	0.469"
1.00"	1.843"	0.797"
1.25"	2.125"	0.880"
1.50"	2.156"	0.880"
2.00"	2.375"	0.911"
2.50"	2.437"	0.912"
3.00"	2.500"	0.907"
4.00"	2.559"	0.888"
5.00"	2.594"	0.469"
6.00"	2.781"	0.469"

Note: Continental ContiTech Insta-Lock fittings are never to be used in steam or compressed air service. Continental ContiTech Insta-Lock cam arms are designed exclusively for Insta-Lock fittings.

Warning: Dust Caps and Dust Plugs are not to be used in pressure applications.

Insta-Lock™ Interlocking Ferrules



Materials

304# Stainless Steel

Part Number System

FR = Ferrule

SS = Stainless Steel

First 3 digits = Inside Diameter of Hose

Fourth digit = Inside Diameter of Ferrule in inches

Fifth and Sixth digits = Inside Diameter of Ferrule in 64ths of an inch

Size	Part #	SAP Reference	Size	Part #	SAP Reference	Size	Part #	SAP Reference
0.50"	FRSS050060	20244292	1.50"	FRSS150156	20148420	3.00"	FRSS300332	20149843
	FRSS050100	20244294		FRSS150160	20148421		FRSS300336	20147831
	FRSS050104	20244300		FRSS150200	20148423		FRSS300340	20148440
	FRSS050108	20244303		FRSS150204	20147837		FRSS300344	20145617
	FRSS050112	20244304		FRSS150208	20145612		FRSS300348	20147870
	FRSS050116	20244306		FRSS150212	20147838		FRSS300352	20145618
	FRSS050120	20244308		FRSS150216	20145613		FRSS300356	20147832
0.75"	FRSS075112	20244604	2.00"	FRSS150220	20148424	4.00"	FRSS300360	20145619
	FRSS075116	20244605		FRSS200232	20147818		FRSS300400	20148441
	FRSS075120	20244606		FRSS200236	20147836		FRSS300404	20148442
	FRSS075124	20244607		FRSS200240	20148425		FRSS400436	20149844
	FRSS075128	20244608		FRSS200244	20148422		FRSS400440	20149845
	FRSS075132	20244620		FRSS200248	20147839		FRSS400444	20148443
	FRSS075136	20244621		FRSS200252	20148426		FRSS400448	20145630
1.00"	FRSS100124	20149821	2.50"	FRSS200256	20148427	FRSS400452	20147871	
	FRSS100128	20149822		FRSS200260	20148428		FRSS400456	20148444
	FRSS100132	20149823		FRSS200300	20148429		FRSS400460	20148445
	FRSS100136	20147814		FRSS250256	20149826		FRSS400500	20148446
	FRSS100140	20147815		FRSS250260	20149827		FRSS400504	20148447
	FRSS100144	20309640		FRSS250300	20149828			
	FRSS100148	20196829		FRSS250304	20149829			
1.25"	FRSS125144	20149824	FRSS250308	20149840				
	FRSS125148	20149825		FRSS250312	20147819			
	FRSS125152	20147816		FRSS250316	20147830			
	FRSS125156	20147817		FRSS250320	20149841			
	FRSS125160	20287731		FRSS250324	20149842			
			FRSS250328	20291545				

Insta-Lock™ Interlocking Ferrules

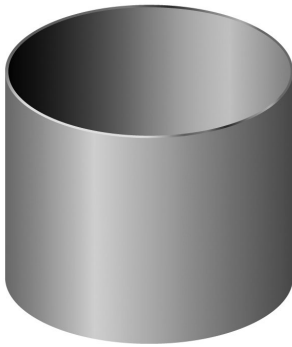

Materials

304# Stainless Steel

Part Number System

SL = Crimp Sleeves

SS = Stainless Steel

First 3 digits = Inside Diameter of Hose

Fourth digit = Inside Diameter of Sleeve in inches

Fifth and Sixth digits = Inside Diameter of Sleeve in 64ths of an inch

Size	Part #	SAP Reference	Size	Part #	SAP Reference	Size	Part #	SAP Reference
1.50"	CSSS150200	20244328	2.50"	CSSS250300	20244440	4.00"	CSSS400436	20244455
	CSSS150204	20244329		CSSS250304	20244441		CSSS400440	20244456
	CSSS150208	20244330		CSSS250308	20244442		CSSS400444	20244457
	CSSS150212	20244331		CSSS250312	20244443		CSSS400448	20244458
	CSSS150216	20244332		CSSS250316	20244444		CSSS400452	20244459
	CSSS150220	20244333		CSSS250320	20244445		CSSS400456	20244470
	CSSS150224	20244334		CSSS250324	20244446		CSSS400460	20244478
	CSSS200232	20244335		CSSS250334	20177492		CSSS400500	20421727
	CSSS200236	20244336		CSSS300336	20244447		CSSS400502	20161402
	CSSS200240	20244338		CSSS300340	20244448			
2.00"	CSSS200244	20244340	3.00"	CSSS300344	20244449			
	CSSS200248	20244342		CSSS300348	20244450			
	CSSS200252	20244344		CSSS300352	20244451			
	CSSS200256	20244346		CSSS300356	20244452			
	CSSS200300	20421752		CSSS300400	20244453			
	CSSS250302	20177491		CSSS300402	20161401			

Insta-Lock™ Repair Kits



Materials

316# Stainless Steel and Brass

Order Codes

Stainless Steel: 605-855

Brass: 605-856

Kit Includes

1 handle, 1 finger ring, 1 pin

Part Number System

First 3 digits = Size

S = Stainless Steel

B = Brass

C = Continental ContiTech Insta-Lock Handle

M = Music Wire Ring

P = Pin

Size	Stainless Steel	SAP Reference	Brass	SAP Reference
0.50"	050SGMP	20297366	050BGMP	20297365
0.75"	100SGMP	20143378	100BGMP	20143421
1.00"	100SGMP	20143378	100BGMP	20143421
1.25"	150SGMP	20147812	150BGMP	20147813
1.50"	150SGMP	20147812	150BGMP	20147813
2.00"	200SGMP	20143379	200BGMP	20143422
2.50"	200SGMP	20143379	200BGMP	20143422
3.00"	300SGMP	20143420	300BGMP	20143423
4.00"	300SGMP	20143420	300BGMP	20143423
5.00"	600SGMP	20453356	600BGMP	20297147
6.00"	600SGMP	20453356	600BGMP	20297147

Insta-Lock™ Gaskets



Materials

Nitrile, Viton®, Teflon® Encapsulated Viton, White Neoprene, Neoprene, Silicone

Order Codes

Nitrile: 605-849 • Viton: 605-852 • Teflon: 605-851
White Neoprene: 605-852 • Neoprene: 605-853
Silicone: 605-854

Part Number System

G = Gasket
First 3 digits = Size of Gasket
Letters = Gasket Material Code

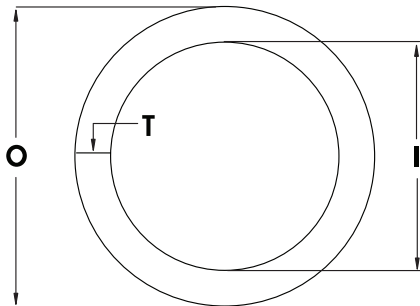

See next page for detailed specifications.

Insta-Lock™ Gaskets

Size	Nitrile	SAP Reference	Viton®	SAP Reference
0.50"	G050BN	20297421	G050VT	20297512
0.75"	G075BN	20297422	G075VT	20297513
1.00"	G100BN	20140981	G100VT	20140988
1.25"	G125BN	20140982	G125VT	20140989
1.50"	G150BN	20140983	G150VT	20140990
2.00"	G200BN	20140984	G200VT	20140991
2.50"	G250BN	20140985	G250VT	20140992
3.00"	G300BN	20140986	G300VT	20140993
4.00"	G400BN	20140987	G400VT	20140994
5.00"	G500BN	20286275	G500VT	20297516
6.00"	G600BN	20295644	G600VT	20260455

Size	Teflon® Encapsulated Viton	SAP Reference	White Neoprene	SAP Reference
0.50"	G050TE	20297507	G050WN	20297517
0.75"	G075TE	20297508	G075WN	20297518
1.00"	G100TE	20141028	G100WN	20141055
1.25"	G125TE	20141029	G125WN	20141056
1.50"	G150TE	20141050	G150WN	20141106
2.00"	G200TE	20141051	G200WN	20141107
2.50"	G250TE	20141052	G250WN	20141108
3.00"	G300TE	20141053	G300WN	20141109
4.00"	G400TE	20141054	G400WN	20141120
5.00"	G500TE	20297509	G500WN	20297519
6.00"	G600TE	20297510	G600WN	20297520

Size	Neoprene	SAP Reference	Silicone	SAP Reference
0.50"	G050NE	20297423	G050SL	20297427
0.75"	G075NE	20297424	G075SL	20297429
1.00"	G100NE	20141121	G100SL	20141407
1.25"	G125NE	20141122	G125SL	20141408
1.50"	G150NE	20141123	G150SL	20141409
2.00"	G200NE	20141403	G200SL	20141430
2.50"	G250NE	20141404	G250SL	20141431
3.00"	G300NE	20141405	G300SL	20141432
4.00"	G400NE	20141406	G400SL	20141433
5.00"	G500NE	20297425	G500SL	20297451
6.00"	G600NE	20297426	G600SL	20297452

Insta-Lock™ Jump Sizes



Spool Adapters

Size	Jump Description	SAP Reference
2" x 2"	AA200AL 2 Spool Adapter Aluminum	20668616
3" x 3"	AA300AL 3 Spool Adapter Aluminum	20668617
4" x 4"	AA400AL 4 Spool Adapter Aluminum	20668618



Female Coupler and Male Thread

Size	Jump Description	SAP Reference
3" x 4"	B3040AL B-3 Coupler x 4 Male NPT	20668619
4" x 3"	B4030AL B-4 Coupler x 3 Male NPT	20668770



Female Coupler and Hose End

Size	Jump Description	SAP Reference
3" x 4"	C3040AL C-3 Coupler x 4 Hose End	20668771
4" x 3"	C4030AL C-4 Coupler x 3 Hose End	20668772

Insta-Lock™ Jump Sizes

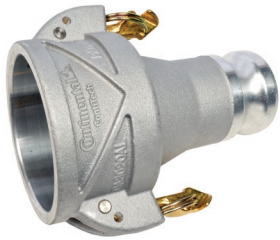

Female Coupler and Male Adapter

Size	Jump Description	SAP Reference
2" x 3"	DA2030AL 2" CPLR x 3 Adapter Aluminum	20668773
3" x 2"	DA3020AL 3" CPLR x 2 Adapter Aluminum	20668774
3" x 4"	DA3040AL 3" CPLR x 4 Adapter Aluminum	20668775
4" x 3"	DA4030AL 4" CPLR x 3 Adapter Aluminum	20668776
6" x 4"	DA6040AL 6" CPLR x 4 Adapter Aluminum	20668777



Female Coupler and Female Coupler

Size	Jump Description	SAP Reference
2" x 2"	DD200AL 2" Double D Alum C & G	20668778
3" x 3"	DD300AL 3" Double D Alum C & G	20668779
4" x 4"	DD400AL 4" Double D Alum C & G	20668780

Continental ContiTech Chemical Hose Tube Polymers

Polymer Code	Polymer Name
1	Ultra High Molecular Weight Polyethylene
2	Butyl
3	Hypalon®
4	Natural Rubber
5	Viton®
6	Nitrile
7	Chlorinated Polyethylene
8	EPDM
9	Polyethylene
10	Modified Polyethylene
11	Teflon® (FEP)

Continental ContiTech Fittings	Material Name
Insta-Lock™	316 Stainless Steel
Insta-Lock	Aluminum

Gasket Code	Polymer Name
T	Teflon
V	Viton
B	Nitrile
N	Neoprene
S	Silicone

Viton, Teflon, Hypalon are registered trademarks of DuPont.

Insta-Lock Pressure Rating Chart

Size	PSI*
0.50"	250
0.75"	250
1.00"	250
1.25"	250
1.50"	250
2.00"	250
2.50"	150
3.00"	150
4.00"	150
5.00"	75
6.00"	75

*Recommended working pressure ratings based on ambient temperature 70°F (21°C).

Continental ContiTech Chemical Resistance Charts

Ratings & Definitions

Continental ContiTech Chemical Resistance Chart is to be used as a guide only.

- A** The chemical is expected to have a minor or no effect on the hose. Hose may be used for continuous service. Changes in working conditions, such as concentration of the chemical or temperature, may affect hose performance and cause degradation of the hose.
- B** The hose may be used for continuous or intermittent service; however, the hose properties will be affected by the exposure to the chemical. Changes in working conditions, such as concentration of the chemical or temperature, may affect hose performance and cause degradation of the hose.
- X** The hose should not be used with this chemical.
- I** Insufficient or no data available for this chemical. Further testing is recommended to determine compatibility of the chemical with the hose.

Caution

Unless otherwise specified, the ratings applied to tube stocks are based on fully concentrated or saturated solutions at 100° F (38°C) under normal service conditions.

Note

Ratings are for the effect on the polymer only. The degree of resistance of a rubber compound to a specific chemical depends on many variables such as temperature, concentration, length of exposure, stability of chemical, etc. For a specific compound, many grades of polymers are available which can alter the compound's chemical resistance.

Ratings are not warranted. The information contained in this chart is believed to be accurate but is not warranted. Customer agrees that in the selection or use of hose products, customer is not relying on any oral or written statements or samples provided by Continental ContiTech. Customer assumes all risk of inaccurate specifications or improper selection or use of the products. For further limitations of liability, see Continental ContiTech's Terms and Conditions of sale.

When in doubt, before using a specific hose, contact your local Continental ContiTech Sales Representative for assistance if unusual service conditions or high temperatures are present in the hose application.

This Chemical Resistance Chart supersedes all previously published information regarding Continental ContiTech chemical hose resistance ratings.

T = Teflon® N = Neoprene
 V = Vitron® S = Silicone
 B = Nitrile

	1	2	3	4	5	6	7	8	9	10	11	Insta-Lock™				
									Blue Flexwing®							
	Temp. (F°)	Fabchem™	Gray Flexwing®	Yellow Flexwing®	Tan Flexwing®	Orange Flexwing®	Petroleum Flexwing®	Brown Flexwing®	Purple Flexwing®	Green XLPE	Viper™	HI-PER®	316 SS	Aluminum	Gasket	
A																
Acetaldehyde	100	B	B	X	X	X	X	I	A	A	A	A	A	B	T S	
Acetic Acid, Conc.	100	A	A	X	B	X	X	A	A	A	A	A	A	B	T	
Acetic Acid, Dilute 10	150	B	A	X	A	X	X	A	A	A	A	A	A	I	T V N	
Acetic Acid, Glacial	100	A	B	X	X	X	X	A	A	A	A	A	A	B	T S	
Acetic Aldehyde	100	A	B	X	X	X	X	I	A	A	A	A	A	B	T	
Acetic Anhydride	100	B	A	B	X	X	X	A	A	A	A	A	A	B	T S	
Acetic Ester	100	B	B	X	X	X	X	B	A	A	A	A	A	A	T V	
Acetic Ether	100	B	B	X	X	X	X	B	A	A	A	A	A	A	T	
Acetic Oxide	100	B	A	B	X	X	X	A	A	A	A	A	A	B	T	
Acetone	100	A	A	X	B	X	X	A	A	A	A	A	A	A	T	
Acetone Cyanohydrin	100	B	A	X	X	X	X	A	A	A	A	A	I	I	T S	
Acetyl Acetone	100	B	B	X	X	X	X	B	I	A	A	A	I	B	T	
Acetyl Chloride	100	B	X	X	X	B	X	A	B	B	A	A	B	X	T V	
Acetyl Oxide	100	B	A	B	X	X	X	A	A	A	A	A	A	B	T	
Acetylene	100	A	A	A	A	A	A	A	A	A	X	A	A	I	TVBNS	
Acetylene Dichloride	100	B	X	X	X	A	X	I	I	A	X	A	I	A	T V	
Acetylene Tetrachloride	100	B	X	X	X	A	X	I	I	A	I	A	A	X	T V	
Acrolein	100	B	A	B	B	A	B	I	I	A	A	A	I	I	T V	
Acrylic Acid	100	B	X	X	X	A	X	X	X	A	A	A	A	I	T V	
Acrylonitrile	100	B	X	X	X	X	X	A	X	B	A	A	A	X	T	
Alk-Tri	100	I	X	X	X	A	X	I	I	A	I	A	A	I	T V	
Allyl Alcohol	100	A	A	A	A	B	A	A	A	A	A	A	A	I	T B N	
Allyl Bromide	100	B	X	X	X	B	X	B	I	B	I	A	I	I	T	
Allyl Chloride	100	B	X	X	X	B	X	B	X	B	I	A	A	X	T S	
Alum	150	A	A	A	A	A	A	A	A	A	A	A	A	I	TVBNS	
Aluminum Acetate	100	A	A	A	X	X	X	A	A	A	A	A	A	I	T	
Aluminum Chloride	150	A	A	A	A	A	A	A	A	A	A	A	I	I	T V B	
Aluminum Formate	100	A	B	X	X	X	X	I	I	A	A	A	I	I	T	
Aluminum Hydroxide	150	A	A	B	A	X	B	A	A	A	A	A	A	I	T S	
Aluminum Sulfate	150	A	A	A	A	A	A	A	A	A	A	A	A	X	TVBNS	
Aminoethanol	100	A	A	B	B	I	B	A	I	A	A	A	A	B	T B N	
Aminoethylethanolamine	100	A	A	B	B	I	B	A	I	A	A	A	I	I	T	
Ammonia	---	No Hose Recommended for this Application											A	I		
Ammonia Cupric Sulfate	150	A	A	A	X	A	A	A	A	A	A	A	A	I	I	T V B
Ammonium Chloride	150	A	A	A	A	A	A	A	A	A	A	A	A	X	TVBN	
Ammonium Hydroxide	150	A	A	B	A	X	X	A	X	A	A	A	A	X	T N S	
Ammonium Nitrate	150	A	A	A	A	A	A	A	A	A	A	A	A	B	TVBS	
Ammonium Phosphate	150	A	A	A	A	A	A	A	A	A	A	A	A	X	TVBNS	
Ammonium Sulfate	150	A	A	A	A	A	X	A	A	A	A	A	A	X	TVNS	
Ammonium Sulfide	150	A	A	A	A	A	X	A	A	A	A	A	A	X	T V N	

Temperature 100°F (38°C) and 150°F (66°C).

Polymer Code

A = May be used for continuous service **X** = Do not use
B = May be used for intermittent service **I** = Insufficient data

T = Teflon® **N** = Neoprene
V = Vitron® **S** = Silicone
B = Nitrile

	1	2	3	4	5	6	7	8	9	10	11	Insta-Lock™		
									Blue Flexwing®					
Temp. (F°)	Fabchem™	Gray Flexwing®	Yellow Flexwing®	Tan Flexwing®	Orange Flexwing®	Flexwing® Petroleum	Brown Flexwing®	Purple Flexwing®	Green XLPE	Viper™	HI-PER®	316 SS	Aluminum	Gasket
A														
Ammonium Sulfite	150	A	A	A	A	A	A	A	A	A	A	A	X	TVBN
Ammonium Thiosulfate	100	A	A	A	A	A	A	A	A	A	A	A	B	TVBN
Amyl Acetate	100	A	A	B	X	X	X	X	B	A	A	A	A	T
Amyl Alcohol	100	A	A	A	A	B	A	A	A	A	A	A	I	TBNS
Amyl Chloride	100	A	X	X	X	A	X	X	X	A	B	A	A	X
Amyl Oleate	100	A	X	X	X	I	B	I	I	A	I	A	I	T
Amyl Phenol	100	A	X	X	X	A	X	I	I	A	I	A	I	T V
Amyl Phthalate	100	A	A	X	X	X	X	I	I	A	I	A	I	T
Amylamine	100	A	B	X	X	X	X	B	X	A	I	A	I	T
Anethole	100	X	X	X	X	B	X	X	I	X	I	A	I	T
Anhydrous Ammonia	---	No Hose Recommended for this Application										A	I	
Aniline	100	A	A	X	X	A	X	B	A	A	A	A	A	B
Animal Grease	100	A	X	X	X	A	A	B	X	A	A	A	A	T V B
Animal Oils	100	A	B	X	X	A	A	A	X	A	B	A	A	T V B
Antimony Pentachloride	100	A	X	X	X	I	X	I	X	B	B	A	I	T
Aqua Ammonia	150	A	A	B	A	A	B	B	B	A	A	A	A	X
Aromatic Spirits	100	A	X	X	X	A	X	I	X	A	I	A	A	I
Aromatic Tar	100	A	X	X	X	A	X	B	X	A	I	A	I	T V
Arquads	100	A	A	A	A	A	A	A	A	A	A	A	I	T V B
Arsenic Acid	100	A	A	A	A	I	X	A	A	A	A	A	A	X
Arsenic Chloride	100	I	X	X	X	X	X	X	X	X	X	A	I	T N
Arsenic Trichloride	100	I	X	X	X	X	X	X	X	X	X	A	X	T N
Asphalt	---	Special Hose Required										A	I	T V N
ASTM #1 Oil	100	A	X	B	X	A	A	A	X	A	A	A	A	TVBNS
ASTM #2 Oil	100	A	X	X	X	A	A	A	X	A	A	A	A	T V B
ASTM #3 Oil	100	A	X	X	X	A	A	A	X	A	A	A	A	T V B
B														
Barium Carbonate	150	A	A	A	A	A	A	A	A	A	A	A	A	X
Barium Chloride	150	A	A	A	A	A	A	A	A	A	A	A	A	X
Barium Hydroxide	150	A	A	A	A	B	A	A	A	A	A	A	A	TBNS
Barium Sulfate	150	A	A	A	A	A	A	A	A	A	A	A	B	TVBS
Barium Sulfide	150	A	A	A	A	A	A	A	A	A	A	A	A	X
Benzal Chloride	100	A	B	I	I	I	X	X	I	A	I	A	B	T
Benzaldehyde	100	A	B	X	X	X	X	X	B	A	B	A	A	B
Benzene (Benzol)	100	I	X	X	X	A	X	X	X	A	I	A	A	T V
Benzine (Ligroin)	100	A	X	X	X	A	A	I	X	A	B	A	A	T V B
Benzine Solvent (Ligroin)	100	A	X	X	X	A	A	I	X	A	I	A	A	TVBS
Benzoic Acid	100	A	B	B	X	I	I	A	B	A	A	A	B	T V N
Benzoic Aldehyde	100	A	B	X	X	X	X	X	B	A	I	A	A	T
Benzotrichloride	100	X	I	I	I	I	X	X	X	X	X	A	I	T
Benzoyl Chloride	100	X	I	I	I	I	X	X	X	B	X	A	B	T
Benzyl Acetate	100	A	A	B	X	X	X	B	I	A	B	A	B	T

Temperature 100°F (38°C) and 150°F (66°C).

Polymer Code

A = May be used for continuous service **X** = Do not use
B = May be used for intermittent service **I** = Insufficient data

T = Teflon® **N** = Neoprene
V = Vitron® **S** = Silicone
B = Nitrile

	1	2	3	4	5	6	7	8	9	10	11	Insta-Lock™			
									Blue Flexwing®						
	Temp. (F°)	Fabchem™	Gray Flexwing®	Yellow Flexwing®	Tan Flexwing®	Orange Flexwing®	Petroleum Flexwing®	Brown Flexwing®	Purple Flexwing®	Green XLPE	Viper™	HI-PER®	316 SS	Aluminum	Gasket
B															
Benzyl Alcohol	100	A	A	X	X	A	X	A	X	A	A	A	A	B	T V S
Benzyl Chloride	100	A	X	X	X	A	X	X	X	A	I	A	A	X	T V
Bichromate of Soda	150	A	A	X	I	I	I	I	I	A	A	A	I	I	T
Black Sulfate Liquor	150	A	X	B	B	B	B	A	B	A	A	A	A	X	TVBN
Black Sulfate Liquor	275	X	X	X	X	X	X	A	X	X	X	A	A	X	T
Bleach	100	X	B	X	X	B	X	I	A	X	B	A	X	X	T V
Brine	150	A	A	A	A	A	A	A	A	A	A	A	A	X	TVBNS
Bromine	100	X	X	X	X	B	X	I	X	X	X	A	X	X	T V
Bromo Benzene	100	B	X	X	X	B	X	X	X	X	X	A	I	I	T V
Bromo Toluene	100	X	X	X	X	B	X	X	X	X	X	A	I	I	T
Bromochloromethane	100	X	B	X	X	B	X	X	I	X	A	A	A	X	T
Bunker C.	100	B	X	X	X	A	A	I	X	A	B	A	A	I	T V B
Bunker Oil	100	B	X	X	X	A	A	I	X	X	B	A	A	I	T V B
Butanol	100	A	A	A	A	B	A	A	A	A	A	A	A	I	T B N
Butyl (Normal) Alcohol	100	A	A	A	A	B	A	A	A	A	A	A	A	I	T B N
Butyl (Secondary) Alcohol	100	A	A	A	A	B	A	A	A	A	A	A	A	I	T B N
Butyl Acetate	100	A	A	B	X	X	X	B	B	A	B	A	A	B	T
Butyl Acetoacetate	100	A	X	X	X	X	X	X	I	A	B	A	I	I	T
Butyl Acrylate	100	B	X	X	X	X	X	B	X	B	B	A	I	I	T
Butyl Alcohol	100	A	A	A	A	B	A	A	A	A	A	A	A	I	T B N
Butyl Aldehyde	100	A	B	X	X	X	X	B	X	A	B	A	X	A	T
Butyl Amine	100	A	B	X	X	X	X	B	X	A	B	A	A	A	T
Butyl Benzene	100	A	X	X	X	A	X	X	X	A	B	A	I	I	T V
Butyl Benzl Phthalate	100	A	A	X	X	X	X	I	I	A	I	A	I	I	T
Butyl Bromide	100	B	X	X	X	B	X	X	X	B	B	A	I	I	T
Butyl Butyrate	100	B	X	X	X	X	X	X	I	B	I	A	I	I	T V
Butyl Carbitol	100	A	A	A	X	I	X	A	B	A	A	A	I	I	T
Butyl Cellosolve	100	A	A	A	X	X	X	A	A	X	A	A	A	A	T
Butyl Chloride	100	B	X	X	X	A	X	X	I	B	I	A	B	I	T V
Butyl Ether	100	A	X	B	X	X	B	A	X	A	A	A	A	I	T
Butyl Ethyl Acetaldehyde	100	A	B	X	X	X	X	I	I	A	B	A	I	I	T
Butyl Ethyl Ether	100	A	X	B	X	I	B	I	X	A	A	A	I	I	T
Butyl Phthalate	100	A	A	X	X	X	X	I	I	A	A	A	A	A	T
Butyl Stearate	100	A	X	X	X	I	A	B	X	A	B	A	A	A	T B S
Butylate	100	A	I	I	I	I	I	I	A	I	I	I	I	I	
Butyraldehyde	100	A	B	X	X	X	X	B	X	A	B	A	X	A	T
Butyric Acid	100	A	X	B	X	I	X	A	B	A	A	A	A	B	T
Butyric Anhydride	100	A	X	B	X	I	X	I	I	A	I	A	I	I	T
C															
Cadmium Acetate	100	A	A	A	X	X	X	A	I	A	A	A	I	I	T
Calcium Acetate	100	A	A	A	X	X	X	A	A	A	A	A	A	I	T B
Calcium Aluminate	100	A	A	A	A	A	A	A	A	A	A	A	I	I	T V B

Temperature 100°F (38°C), 150°F (66°C) and 275°F (135°C).

Polymer Code

A = May be used for continuous service **X** = Do not use
B = May be used for intermittent service **I** = Insufficient data

T = Teflon® **N** = Neoprene
V = Vitron® **S** = Silicone
B = Nitrile

	1	2	3	4	5	6	7	8	9	10	11	Insta-Lock™		
									Blue Flexwing®					
Temp. (F°)	Fabchem™	Gray Flexwing®	Yellow Flexwing®	Tan Flexwing®	Orange Flexwing®	Flexwing® Petroleum	Brown Flexwing®	Purple Flexwing®	Green XLPE	Viper™	HI-PER®	316 SS	Aluminum	Gasket
C														
Calcium Bichromate	150	X	A	X	I	I	I	I	X	I	A	I	I	T
Calcium Bisulfate	150	A	A	A	A	A	A	A	A	A	A	A	X	TVBN
Calcium Bisulfite	150	A	A	A	A	A	A	A	I	A	A	A	X	TVBNS
Calcium Carbonate	150	A	A	A	A	A	A	A	A	A	A	A	I	TVBNS
Calcium Chloride	150	A	A	A	A	A	A	A	A	A	A	B	X	TVBNS
Calcium Hydroxide (Caustic Lime)	100	A	A	B	A	X	B	A	A	A	A	A	X	T N S
Calcium Hypochlorite	100	B	B	X	X	B	X	A	B	X	A	A	X	T V
Calcium Nitrate	150	A	A	A	A	A	A	A	A	A	A	B	X	TVBN
Calcium Silicate	150	A	A	A	A	A	A	A	A	A	A	I	A	TVBN
Calcium Sulfate	150	A	A	A	A	A	A	A	A	A	A	A	I	TVBS
Calcium Sulfhydrate	100	A	A	A	A	A	A	A	A	A	A	I	I	T V B
Calcium Sulfide	150	A	A	A	A	A	A	A	A	A	A	A	X	TVBN
Calcium Sulfite	150	A	A	A	X	A	A	A	A	A	A	B	B	TVBNS
Caprylic Acid	100	A	X	B	X	I	X	A	I	A	A	B	I	T
Carbitol	100	A	A	A	X	I	X	A	A	A	A	B	A	T
Carbitol Acetate	100	A	B	B	X	I	X	I	I	A	A	I	I	T
Carbolic Acid, Phenol	100	A	A	X	X	A	X	A	X	A	B	A	B	T V
Carbon Dioxide	100	A	A	A	A	A	A	A	A	A	A	A	B	TVBNS
Carbon Disulfide	---	No Hose Recommended for this Application										A	A	
Carbon Tetrachloride	100	B	X	X	X	A	X	X	X	A	B	A	I	T V
Carbonic Acid	100	A	A	A	A	A	A	A	A	A	A	A	B	TVBS
Casinghead Gasoline	100	B	X	X	X	A	A	B	X	B	B	A	I	T V B
Caster Oil	100	A	A	A	X	A	A	A	A	A	A	A	A	TVBS
Caustic Potash	150	A	A	B	A	X	B	A	B	A	A	A	X	T
Caustic Soda	150	A	A	B	A	X	B	A	A	A	A	A	X	T N S
Cellosize	100	A	A	X	X	I	X	I	I	A	A	A	I	T
Cellosolve	100	A	A	A	X	X	X	I	A	A	A	A	A	T
Cellosolve Acetate	100	A	B	B	X	X	X	X	B	A	A	A	I	T
Chloracetic Acid	100	A	X	X	B	X	X	A	X	A	A	A	X	T
Chlorinated Solvents	100	B	X	X	X	A	X	B	X	A	I	A	B	T V
Chlorine (Dry)	---	No Hose Recommended for this Application										A	X	
Chlorine (Wet)	100	X	X	X	X	B	X	X	X	X	X	A	X	T V
Chloroacetone	100	A	I	X	X	X	X	X	X	A	I	A	A	T
Chlorobenzene	100	B	X	X	X	A	X	X	X	A	B	A	B	T V
Chlorobenzol	100	A	X	X	X	A	X	I	X	A	B	A	B	T V
Chlorobutane	100	X	X	X	X	A	X	X	I	X	I	A	I	T V
Chloroethylbenzene	100	A	X	X	X	A	X	I	X	A	I	A	I	T V
Chloroform	100	B	X	X	X	B	X	X	X	X	B	A	B	T V
Chloropentane	100	A	X	X	X	A	X	X	X	A	I	A	A	T V
Chlorophenol	100	A	X	X	X	B	X	X	X	X	B	A	I	T V
Chloropropanone	100	A	I	X	X	X	X	X	X	A	I	A	I	T
Chlorosulfonic Acid	100	X	X	X	X	X	X	I	X	X	X	A	B	T

Temperature 150°F (66°C) and 100°F (38°C).

Polymer Code

A = May be used for continuous service **X** = Do not use
B = May be used for intermittent service **I** = Insufficient data

T = Teflon® **N** = Neoprene
V = Vitron® **S** = Silicone
B = Nitrile

	1	2	3	4	5	6	7	8	9	10	11	Insta-Lock™			
									Blue Flexwing®						
	Temp. (F°)	Gray Flexwing®	Yellow Flexwing®	Tan Flexwing®	Orange Flexwing®	Flexwing® Petroleum	Brown Flexwing®	Purple Flexwing®	Green XLPE	Viper™	HI-PER®	316 SS	Aluminum	Gasket	
C															
Chloroethene	100	X	X	X	X	A	X	I	X	A	I	A	A	I	T V
Chlorotoluene	100	X	X	X	X	A	X	X	X	X	I	A	A	I	T V
Chlorpyrifos	100	I	I	I	I	I	I	I	X	I	I	I	I	I	
Chromic Acid (25%)	100	B	X	B	X	I	X	A	X	X	B	A	B	X	T V
Coal Oil	100	A	X	X	X	A	A	A	X	A	A	A	A	X	T V B
Coal Tar	100	A	X	X	X	A	X	B	X	A	A	A	A	I	T V S
Coal Tar Naptha	100	A	X	X	X	A	X	B	X	A	A	A	A	A	T V
Copper Chloride	100	A	A	A	X	A	A	A	A	A	A	A	X	X	TVBNS
Copper Hydrate	100	A	A	B	X	X	B	I	I	A	A	A	I	I	T B
Copper Hydroxide	100	A	A	B	X	X	B	I	I	A	A	A	I	I	T B
Copper Nitrate	100	A	A	A	X	A	A	A	A	A	A	A	A	X	TVBNS
Copper Nitrite	100	A	A	A	X	A	A	A	A	A	A	A	I	I	T V B
Copper Sulfate	100	A	A	A	X	A	A	A	A	A	A	A	A	X	TVBNS
Copper Sulfide	100	A	A	A	X	A	A	A	A	A	A	A	I	I	T V B
Creosols	100	A	A	X	X	A	X	A	X	A	B	A	A	I	T V
Creosote	100	A	X	X	X	A	B	I	X	A	B	A	A	I	T V
Cresylic Acid	100	A	A	X	X	I	X	X	X	A	I	A	A	B	T V
Crotonaldehyde	100	A	A	X	X	X	X	A	I	A	A	A	I	I	T
Crude Oil	100	A	X	X	X	A	A	B	X	A	B	A	A	A	T V B
Cumene	100	A	X	X	X	A	X	X	X	A	B	A	I	I	T V
Cupric Carbonate	100	A	A	A	X	A	A	A	A	A	A	A	I	I	TVBN
Cupric Chloride	100	A	A	A	X	A	A	A	A	A	A	B	X		TVBNS
Cupric Nitrate	100	A	A	A	X	A	A	A	A	A	A	A	B	I	TVBN
Cupric Nitrite	100	A	A	A	X	A	A	A	A	A	A	A	I	I	T V B
Cupric Sulfate	100	A	A	A	X	A	A	A	A	A	A	A	I	I	TVBNS
Cyclohexane	100	A	X	X	X	A	B	A	X	A	B	A	A	B	T V
Cyclohexanol	100	A	X	X	X	B	B	A	X	A	B	A	A	X	T V B
Cyclohexanone	100	A	X	X	X	X	X	X	X	A	B	A	A	I	T
Cyclopentane	100	A	X	X	X	A	B	B	X	A	B	A	I	I	T V N
Cyclopentane, methyl	100	A	X	X	X	A	B	I	X	A	B	A	I	I	T V
Cyclopentanol	100	A	X	X	X	B	B	A	X	A	A	A	I	I	T V B
Cyclopentanone	100	A	X	X	X	X	X	X	X	A	B	A	I	I	T
D															
D.D.T. in Kerosene	100	A	X	X	X	A	A	A	X	A	B	A	I	I	T V B
D.M.P.	100	X	X	X	X	X	X	X	X	X	A	A	A	I	T V
Decalin	100	X	X	X	X	A	X	X	X	A	X	A	I	I	T V
Decanol	100	A	A	A	X	B	A	A	A	A	A	A	I	I	T B
Decyl Alcohol	100	A	A	A	X	B	A	A	A	A	A	A	I	I	T B
Decyl Aldehyde	100	A	X	X	X	X	X	I	I	A	B	A	I	I	T
Decyl Butyl Phthalate	100	A	A	X	X	X	X	I	I	A	I	A	I	I	T
Denatured Alcohol	100	A	A	A	A	B	A	A	A	A	A	A	A	B	T B
Diacetone Alcohol	100	A	A	B	B	X	X	A	X	A	A	A	A	I	T

Temperature 100°F (38°C).

Polymer Code

A = May be used for continuous service **X** = Do not use
B = May be used for intermittent service **I** = Insufficient data

T = Teflon® **N** = Neoprene
V = Vitron® **S** = Silicone
B = Nitrile

	1	2	3	4	5	6	7	8	9	10	11	Insta-Lock™			
									Blue Flexwing®						
Temp. (F°)	Fabchem™	Gray Flexwing®	Yellow Flexwing®	Tan Flexwing®	Orange Flexwing®	Flexwing® Petroleum	Brown Flexwing®	Purple Flexwing®	Green XLPE	Viper™	HI-PER®	316 SS	Aluminum	Gasket	
D															
Diarnyl Phenol	100	A	X	X	X	A	X	A	X	A	I	A	I	I	T V
Diarnylamine	100	A	A	X	B	I	B	A	I	A	B	A	I	I	T B
Diarnylene	100	A	X	X	X	A	X	B	X	A	B	A	I	I	T V
Dibenzyl Ether	100	A	B	X	X	I	X	X	X	A	B	A	A	A	T
Dibromobenzene	100	B	X	X	X	A	X	I	X	A	I	A	I	I	T V
Dibutyl Amine	100	A	X	X	B	X	B	A	X	A	A	A	I	I	T
Dibutyl Ether	100	A	X	B	X	X	X	A	X	A	A	A	A	A	T
Dibutyl Phthalate	100	A	A	X	X	X	X	X	A	A	A	A	A	A	T V
Dibutyl Sebacate	100	A	A	X	X	X	X	B	X	A	I	A	I	I	T V S
Dicalcium Phosphate	100	A	A	A	A	A	A	A	A	A	A	A	I	I	T V B
Dicamba	100	A	I	I	I	I	I	I	A	A	I	A	I	I	T
Dichloroacetic Acid	100	A	X	X	B	X	X	B	I	A	I	A	I	I	T
Dichlorobenzene	100	A	X	X	X	A	X	X	X	A	B	A	A	B	T V
Dichlorobutane	100	A	X	X	X	A	X	X	X	A	I	A	I	I	T V
Dichlorodifluoromethane	100	I	X	X	X	B	B	I	X	I	X	A	I	I	T V B
Dichloroethane	100	A	X	X	X	A	X	X	X	A	A	A	I	A	T V
Dichloroethyl Ether	100	A	X	X	X	I	X	B	X	A	B	A	I	I	T
Dichloroethylene	100	X	X	X	X	A	X	I	I	X	X	A	I	A	T V
Dichlorohexane	100	A	X	X	X	A	X	X	X	A	A	A	I	I	T V
Dichloromethane	100	A	X	X	X	A	X	X	X	A	A	A	A	B	T V
Dichloropentane	100	A	X	X	X	A	X	X	X	A	B	A	I	I	T V
Dichloropropane	100	A	X	X	X	A	X	X	X	B	I	A	A	X	T V
Diesel Oil	150	A	X	X	X	A	A	A	X	A	B	A	A	A	T V B
Diethanol Amine	100	A	A	X	B	I	B	A	I	A	A	A	A	I	T
Diethyl Benzene	100	A	X	X	X	A	X	X	X	A	B	A	I	I	T V
Diethyl Carbinol	100	A	A	A	A	B	A	I	I	A	A	A	I	I	T B N
Diethyl Ketone	100	A	B	X	X	X	X	X	X	A	B	A	I	I	T
Diethyl Oxalate	100	A	B	X	B	I	X	A	X	A	B	A	I	I	T
Diethyl Phthalate	100	A	A	X	X	X	X	B	X	A	B	A	I	I	T
Diethyl Sebacate	100	A	A	X	X	X	X	B	X	A	B	A	A	A	T
Diethyl Sulfate	100	A	B	X	X	X	X	A	I	A	A	A	X	I	T N S
Diethyl Triamine	100	A	A	X	B	I	B	A	I	A	A	A	I	I	T B
Diethylamine	100	A	A	X	B	I	B	B	B	A	B	A	A	I	T B
Diethylene Dioxide	100	A	B	X	X	X	X	B	A	A	A	A	X	X	T
Diethylene Glycol	100	A	A	A	A	A	A	X	A	A	A	A	A	B	T V B N
Diethylene Triamine	100	A	A	X	B	I	B	A	I	A	A	A	I	I	T
Dihydroxydiethyl Ether	100	A	A	A	A	A	A	A	A	A	A	A	I	I	T V B N
Dihydroxyethyl Amine	100	A	A	X	B	I	B	A	I	A	A	A	I	I	Y B
Diisobutyl Ketone	100	A	B	X	X	X	X	I	B	A	B	A	I	I	T
Diisobutylene	100	A	X	X	X	A	A	X	X	A	B	A	A	I	T V B
Diisooctyl Adipate	100	A	A	X	X	X	X	I	I	A	I	A	I	I	T
Diisooctyl Phthalate	100	A	A	X	X	X	X	I	I	A	I	A	I	I	T

Temperature 150°F (66°C) and 100°F (38°C).

Polymer Code

A = May be used for continuous service **X** = Do not use
B = May be used for intermittent service **I** = Insufficient data

T = Teflon® **N** = Neoprene
V = Vitron® **S** = Silicone
B = Nitrile

	1	2	3	4	5	6	7	8	9	10	11	Insta-Lock™		
									Blue Flexwing®					
Temp. (F°)	Fabchem™	Gray Flexwing®	Yellow Flexwing®	Tan Flexwing®	Orange Flexwing®	Flexwing® Petroleum	Brown Flexwing®	Purple Flexwing®	Green XLPE	Viper™	HI-PER®	316 SS	Aluminum	Gasket
D														
Diisocyanate	100	A	X	X	X	X	X	X	A	B	A	I	I	T
Diisodecyl Adipate	100	A	A	X	X	X	I	I	A	I	A	I	I	T
Diisodecyl Phthalate	100	A	A	X	X	X	I	I	A	I	A	I	I	T
Diisopropanol Amine	100	A	A	X	B	I	B	I	A	B	A	I	I	T B
Diisopropyl Amine	100	A	A	X	B	I	B	I	A	B	A	I	I	T B
Diisopropyl Ether	100	A	X	B	X	I	B	I	X	A	B	A	A	T B
Diisopropyl Ketone	100	A	B	X	X	X	I	B	A	B	A	A	A	T
Dilauryl Ether	100	A	I	B	X	I	B	I	A	B	A	I	I	T B
Dimethyl Amine	---	No Hose Recommended for this Application										B	I	
Dimethyl Benzene	100	A	X	X	X	A	X	X	A	B	A	A	I	T V
Dimethyl Ether	100	A	X	B	X	I	B	I	X	B	B	A	I	T B
Dimethyl Ketone	100	A	A	X	B	X	X	A	A	B	A	A	A	T
Dimethyl Phenol	100	A	X	X	X	A	X	I	X	A	A	A	I	T V
Dimethyl Phthalate	100	A	A	X	X	X	A	B	A	A	A	A	I	T V
Dimethyl Sulfate	100	A	B	X	X	X	A	I	A	A	A	I	I	T
Dimethyl Sulfide	---	No Hose Recommended for this Application										I	I	
Dimethyl Carbinol	100	A	A	A	A	B	A	A	A	A	A	A	I	TBNS
Dinitrobenzene	100	A	X	X	X	A	X	I	I	A	B	A	I	T V
Diocetyl Adipate	100	A	A	X	X	X	X	X	B	A	I	A	I	T
Diocetyl Amine	100	A	A	X	B	I	B	I	A	B	A	I	I	T
Diocetyl Phthalate	100	A	B	X	X	A	X	X	A	A	A	A	I	T V
Diocetyl Sebacate	100	A	A	X	X	X	X	X	B	A	I	A	I	T V
Dioxane	100	A	B	X	X	X	X	B	X	A	A	A	A	T
Dioxolane	100	A	X	X	X	I	X	B	X	A	B	A	I	T
Diphenyl Phthalate	100	A	A	X	X	X	X	I	I	A	A	A	I	T
Dipropyl Ketone	100	A	B	X	X	X	X	X	I	A	A	A	I	T
Dipropylamine	100	A	A	X	B	I	B	B	I	A	A	A	I	T
Dipropylene Glycol	100	A	A	A	A	A	A	A	I	A	A	A	I	T V B
Disodium Phosphosphate	100	A	A	A	A	I	A	A	I	A	A	A	A	T B
Divinyl Benzene	100	A	X	X	X	A	X	X	X	A	B	A	I	T V
Dodecyl Benzene	100	A	X	X	X	A	X	I	X	A	B	A	I	T V
Dodecyl Toluene	100	A	X	X	X	A	X	I	X	A	B	A	I	T V
Dow-Per	100	A	X	X	X	A	X	I	X	A	B	A	I	T V
Dowtherm A	100	A	I	X	X	A	X	X	X	A	A	A	I	T V
Dowtherm E	100	A	X	X	X	A	X	X	X	A	A	I	I	X V
Dowtherm SR-1	100	A	A	A	A	A	A	I	I	A	A	A	I	T V B
E														
Endolene	100	I	I	I	I	I	I	I	I	I	I	I	I	
Epichlorohydrate	100	A	X	X	X	X	X	X	X	A	I	I	I	
Ethanol	100	A	A	A	A	B	A	A	A	A	A	A	B	T B N
Ethanol Amine	100	A	A	B	B	I	B	A	B	A	B	A	B	T B
Ethyl Acetate	100	A	B	X	X	X	X	B	A	A	A	A	A	T

Temperature 100°F (38°C).

Polymer Code

A = May be used for continuous service **X** = Do not use
B = May be used for intermittent service **I** = Insufficient data

T = Teflon® **N** = Neoprene
V = Vitron® **S** = Silicone
B = Nitrile

	1	2	3	4	5	6	7	8	9	10	11	Insta-Lock™			
									Blue Flexwing®						
Temp. (F°)	Fabchem™	Gray Flexwing®	Yellow Flexwing®	Tan Flexwing®	Orange Flexwing®	Flexwing® Petroleum	Brown Flexwing®	Purple Flexwing®	Green XLPE	Viper™	HI-PER®	316 SS	Aluminum	Gasket	
E															
Ethyl Acetoacetate	100	A	B	X	X	X	X	A	B	A	A	A	B	I	T
Ethyl Acrylate	100	A	X	X	X	X	X	B	X	B	B	A	A	A	T
Ethyl Alcohol	100	A	A	A	A	A	A	A	A	A	A	A	A	B	TVBNS
Ethyl Aldehyde	---	No Hose Recommended for this Application										A	B	S	
Ethyl Aluminum Dichloride	100	X	X	X	X	B	X	I	X	B	I	A	I	I	TV
Ethyl Benzene	100	A	X	X	X	A	X	X	X	A	B	A	A	A	TV
Ethyl Butanol	100	A	A	A	A	B	A	A	A	A	A	A	I	I	TB
Ethyl Butyl Acetate	100	A	A	B	X	X	X	I	I	A	B	A	I	I	T
Ethyl Butyl Alcohol	100	A	A	A	A	B	A	A	A	A	A	A	I	I	TB
Ethyl Butyl Amine	100	A	A	X	B	I	B	I	I	I	I	A	I	I	TB
Ethyl Butyl Ketone	100	A	B	X	X	X	X	X	I	A	A	A	I	I	T
Ethyl Butyraldehyde	100	A	B	X	X	X	X	X	I	A	B	A	I	I	T
Ethyl Chloride	---	No Hose Recommended for this Application										I	I		
Ethyl Dichloride	100	B	X	X	X	B	X	X	X	B	B	A	I	I	TV
Ethyl Ether	---	No Hose Recommended for this Application										A	A		
Ethyl Formate	100	A	B	X	X	X	X	A	B	A	A	A	A	I	TV
Ethyl Hexanol	100	A	A	A	A	B	A	A	A	A	A	A	I	I	TBN
Ethyl Hexoic Acid	100	A	X	B	X	I	X	I	I	A	A	A	I	I	T
Ethyl Hexyl Acetate	100	A	A	B	X	X	X	I	I	A	B	A	I	I	T
Ethyl Hexyl Alcohol	100	A	A	A	A	B	A	A	A	A	A	A	I	I	TBN
Ethyl Iodide	100	X	X	X	X	B	X	X	X	B	B	A	I	I	TV
Ethyl Isobutyl Ether	100	A	X	B	X	I	B	I	X	A	B	A	I	I	T
Ethyl Methyl Ketone	100	A	B	X	X	X	X	I	I	A	A	A	A	A	T
Ethyl Oxalate	100	A	A	X	A	I	X	A	X	A	B	A	I	I	TV
Ethyl Phthalate	100	A	A	X	X	X	X	B	I	A	I	A	I	I	T
Ethyl Propyl Ether	100	A	X	B	X	I	B	A	X	A	B	A	I	I	TB
Ethyl Propyl Ketone	100	A	B	X	X	X	X	I	I	A	A	A	I	I	T
Ethyl Silicate	100	A	A	I	X	I	A	A	I	A	A	A	A	I	TBN
Ethyl Sulfate	100	A	B	X	X	X	X	A	I	A	A	A	X	I	TBS
Ethylamine	---	No Hose Recommended for this Application										I	I		
Ethylene Bromide	100	X	X	X	X	B	X	I	X	B	B	A	A	X	TV
Ethylene Chloride	100	B	X	X	X	B	X	I	X	B	B	A	A	B	TV
Ethylene Diamine	100	A	A	X	B	I	B	I	B	A	I	A	A	I	TB
Ethylene Dibromide	100	X	X	X	X	B	X	I	X	B	B	A	A	X	TV
Ethylene Dichloride	100	B	X	X	X	B	X	X	X	B	A	A	A	B	TV
Ethylene Glycol	150	A	A	A	A	A	A	A	A	A	A	A	A	A	TVBNS
Ethylhexil Phosphorodieth	100	I	X	X	I	I	A	A	X	X	I	I	I	I	B
Ex-Tri	100	A	X	X	X	A	X	I	I	A	B	A	I	I	TV
F															
Ferric Bromide	150	A	A	A	A	A	A	A	A	A	A	A	I	I	TVB
Ferric Chloride	150	A	A	A	A	A	A	A	A	A	A	A	X	X	TVBNS
Ferric Sulfate	150	A	A	A	A	A	A	A	A	A	A	A	A	X	TVBN

Temperature 150°F (66°C) and 100°F (38°C).

Polymer Code

A = May be used for continuous service **X** = Do not use
B = May be used for intermittent service **I** = Insufficient data

T = Teflon® **N** = Neoprene
V = Vitron® **S** = Silicone
B = Nitrile

	1	2	3	4	5	6	7	8	9	10	11	Insta-Lock™			
									Blue Flexwing®						
	Temp. (F°)	Fabchem™	Gray Flexwing®	Yellow Flexwing®	Tan Flexwing®	Orange Flexwing®	Petroleum Flexwing®	Brown Flexwing®	Purple Flexwing®	Green XLPE	Viper™	HI-PER®	316 SS	Aluminum	Gasket
F															
Ferrous Acetate	100	A	A	A	X	X	X	I	I	A	A	A	I	I	T
Ferrous Chloride	150	A	A	A	A	B	A	A	A	A	A	A	I	X	T B
Ferrous Hydroxide	100	A	A	A	A	A	A	A	A	A	A	A	B	X	T N
Ferrous Sulfate	150	A	A	A	A	A	A	A	A	A	A	A	B	X	TVBN
Fluoboric Acid (65%)	150	B	A	A	A	I	I	A	I	I	A	A	I	I	T N
Fluorine (wet)	100	X	X	X	X	X	X	X	X	X	X	B	X	X	T
Fluosilicic Acid (50%)	150	B	A	A	A	I	I	A	I	I	A	A	A	X	T N
Formaldehyde (40%)	100	A	A	A	B	B	A	A	A	A	A	A	A	B	T B
Formalin	100	A	A	A	B	A	A	A	A	A	A	A	A	B	T V B
Formic Acid	100	A	A	X	B	X	X	A	A	B	A	A	B	I	T V
Freon 12	100	A	X	X	X	B	B	I	X	B	X	A	A	I	T N
Freon 22	100	A	X	X	X	X	X	I	I	B	X	A	A	I	T N
Fuel A (ASTM)	100	B	X	X	X	A	A	I	X	B	B	A	A	A	T V B
Fuel B (ASTM)	100	B	X	X	X	A	A	I	X	B	B	A	I	I	T V B
Fuel Oil	100	A	X	X	X	A	A	X	X	B	B	A	A	A	T V B
Furfural	100	A	A	I	I	X	X	A	B	A	A	A	A	A	T
Furfuryl Alcohol	100	A	X	I	I	X	I	A	I	A	A	A	A	A	T
G															
Gallic Acid	100	A	B	I	A	I	I	A	B	I	B	A	B	I	T S
Gasoline	100	B	X	X	X	A	A	B	X	B	B	A	A	I	T V B
Glacial Acetic Acid	100	A	B	X	X	X	X	B	A	A	A	A	A	B	T
Gluconic Acid	100	A	X	B	X	I	X	A	I	A	A	A	X	X	T
Glycerin	100	A	A	A	A	A	A	A	A	B	A	A	A	A	TVBNS
Glyphosate	100	A	I	I	I	I	I	I	A	I	I	I	I	I	
Graffinite	100	I	X	X	X	X	A	A	X	X	I	I	I	I	B
Grease	100	A	X	X	X	A	A	I	X	B	A	A	A	A	T V B
Green Sulfate Liquor	150	A	A	A	A	I	A	A	A	A	A	A	A	X	T B S
H															
Heptanal	100	A	X	X	X	X	X	X	I	A	I	A	I	I	T B
Heptane	100	A	X	X	X	A	A	A	X	B	B	A	A	A	T V B
Heptane Carboxylic Acid	100	A	X	B	X	A	X	A	I	A	A	A	I	I	T V
Hexaldehyde	100	A	X	X	X	X	X	I	X	A	B	A	A	A	T
Hexane	100	B	X	X	X	A	A	B	X	B	B	A	A	A	T V B
Hexanol	100	A	A	A	A	B	A	A	A	A	A	A	A	I	T B
Hexyl Methyl Ketone	100	A	B	X	X	X	X	I	I	A	A	A	I	I	T
Hexylamine	100	A	B	X	X	X	X	B	I	A	B	A	I	I	T
Hexylene	100	X	X	X	X	A	A	I	X	X	I	A	I	I	T V B
Hexylene Glycol	150	A	A	A	A	A	A	A	I	A	A	A	A	B	TVBN
Hexyl-Alcohol	100	A	A	A	A	B	A	A	X	A	A	A	A	I	T B
Hi-Tri	100	A	X	X	X	A	X	I	X	A	B	A	I	I	T V
Hydrochloric Acid (-38%) Conc.	125	I	A	X	B	I	X	A	B	A	A	A	X	X	T
Hydrobromic Acid (37%)	150	B	A	A	A	I	X	A	A	I	A	A	X	X	T N

Temperature 150°F (66°C), 100°F (38°C) and 125°F (52°C).

Polymer Code

A = May be used for continuous service **X** = Do not use
B = May be used for intermittent service **I** = Insufficient data

T = Teflon® **N** = Neoprene
V = Vitron® **S** = Silicone
B = Nitrile

	1	2	3	4	5	6	7	8	9	10	11	Insta-Lock™			
									Blue Flexwing®						
Temp. (F°)	Fabchem™	Gray Flexwing®	Yellow Flexwing®	Tan Flexwing®	Orange Flexwing®	Flexwing® Petroleum	Brown Flexwing®	Purple Flexwing®	Green XLPE	Viper™	HI-PER®	316 SS	Aluminum	Gasket	
H															
Hydrochloric Acid (37%)	125	A	A	X	B	X	X	A	B	A	A	X	X	T	
Hydrofluoric Acid (10%)	125	A	A	A	X	I	X	A	I	A	A	A	X	T N	
Hydrofluosilicic Acid	150	B	B	A	A	I	I	A	A	I	A	A	X	T	
Hydrogen Dioxide (10%)	100	B	X	X	X	A	X	I	I	I	A	A	B	T V	
Hydrogen Dioxide over (10%)	100	B	X	X	X	I	X	I	X	I	A	I	I	T	
Hydrogen Gas	100	A	A	B	B	I	A	X	A	A	A	A	A	T B	
Hydrogen Peroxide (10% - 50%)	100	B	X	X	X	A	X	A	I	I	A	I	B	T V S	
Hydrogen Peroxide (over 50%)	100	X	X	X	X	X	X	X	X	X	I	A	A	T	
I															
Iodine	100	A	I	A	I	I	I	A	I	B	I	A	I	T V B	
Iron Acetate	100	A	A	A	X	X	X	I	I	A	A	A	I	T N S	
Iron Hydroxide	100	A	A	B	X	X	B	I	I	A	A	A	I	T N	
Iron Salts	150	A	A	A	A	A	A	A	A	A	A	A	I	TVBN	
Iron Sulfate	150	A	A	A	A	A	A	A	A	A	A	A	I	TVBN	
Iron Sulfide	150	A	A	A	A	A	A	A	A	A	A	A	I	T V B	
Isoamyl Acetate	100	A	A	B	X	X	X	I	X	A	B	A	I	T	
Isoamyl Alcohol	100	A	A	A	A	B	A	A	A	A	A	A	I	T B N	
Isoamyl Bromide	100	B	X	X	X	B	X	I	X	B	I	A	I	T V	
Isoamyl Butyrate	100	B	X	X	X	X	X	I	I	B	B	A	I	T	
Isoamyl Chloride	100	X	X	X	X	B	X	I	I	X	B	A	I	T V	
Isoamyl Ether	100	A	X	B	X	I	B	I	X	A	I	A	I	T	
Isoamyl Phthalate	100	A	A	X	X	X	X	I	I	A	I	A	I	T	
Isobutane	---	No Hose Recommended for this Application										A	I		
Isobutanol	100	A	A	A	A	B	A	A	A	A	A	A	A	TBNS	
Isobutyl Acetate	100	A	A	B	X	X	X	B	X	A	B	A	A	T	
Isobutyl Alcohol	100	A	A	A	A	B	X	A	A	A	A	A	A	T N S	
Isobutyl Aldehyde	100	A	B	X	X	X	X	B	I	A	B	A	I	T	
Isobutyl Amine	100	A	B	X	X	X	X	I	I	A	B	A	I	T	
Isobutyl Bromide	100	B	X	X	X	B	X	I	X	X	I	A	I	T V	
Isobutyl Carbinol	100	A	A	A	A	B	A	A	A	A	A	A	A	T B N	
Isobutyl Chloride	100	B	X	X	X	B	X	I	X	X	I	A	I	T V	
Isobutyl Ether	100	A	X	B	X	I	X	I	X	A	I	A	I	T B	
Isobutylene	100	A	X	X	X	A	X	I	X	A	B	A	I	T V	
Isooctane	100	B	X	X	X	A	A	I	X	B	B	A	A	TVBS	
Isopentane	---	No Hose Recommended for this Application										I	I		
Isophorone	100	B	A	I	I	I	X	I	A	B	B	A	B	T	
Isopropanol	100	A	A	A	A	B	A	A	A	A	A	A	A	TVBS	
Isopropanol Amine	100	A	A	X	B	X	B	I	I	A	B	A	I	T B	
Isopropyl Acetate	100	A	A	X	X	X	X	B	X	A	A	A	A	T	
Isopropyl Alcohol	100	A	A	A	A	B	A	A	A	A	A	A	A	TBNS	
Isopropyl Amine	100	A	B	X	X	X	X	I	I	A	B	A	I	T	
Isopropyl Benzene	100	A	X	X	X	A	X	X	X	A	B	A	I	T V	

Temperature 150°F (66°C), 100°F (38°C) and 125°F (52°C).

Polymer Code

A = May be used for continuous service **X** = Do not use
B = May be used for intermittent service **I** = Insufficient data

T = Teflon® **N** = Neoprene
V = Vitron® **S** = Silicone
B = Nitrile

	1	2	3	4	5	6	7	8	9	10	11	Insta-Lock™			
									Blue Flexwing®						
	Temp. (F°)	Gray Fabchem™	Yellow Flexwing®	Tan Flexwing®	Orange Flexwing®	Flexwing® Petroleum	Brown Flexwing®	Purple Flexwing®	Green XLPE	Viper™	HI-PER®	316 SS	Aluminum	Gasket	
I															
Isopropyl Chloride	---	No Hose Recommended for this Application										A	A		
Isopropyl Ether	100	A	X	B	X	I	X	I	X	A	B	A	A	I	T B
Isopropyl Toluene	100	A	X	X	X	A	X	I	X	S	I	A	I	I	T V
J															
Jet Fuels	---	Special Hose Required										A	A	T V B	
K															
Kerosene	100	A	X	X	X	A	B	A	X	A	A	A	A	A	T V B
L															
Lauryl Alcohol	100	A	A	A	A	B	A	A	A	A	A	A	I	I	T B
Lead Acetate	100	A	A	X	X	X	X	A	B	A	A	A	A	X	T
Lead Sulfate	150	A	A	A	A	A	A	A	A	A	A	A	A	X	TVBN
Ligroin	100	A	X	X	X	A	A	I	X	A	B	A	A	A	T V B
Linseed Oil	100	A	A	B	X	A	A	A	B	I	A	A	A	I	TVBNS
Liquefied Natural Gas (LNG)	---	No Hose Recommended for this Application										A	A		
Liquefied Petroleum Gas (LPG)	---	No Hose Recommended for this Application										A	A		
Lubricating Oils	100	A	X	X	X	A	A	I	X	A	I	A	A	A	T V B
M															
MIBK	100	A	B	X	X	X	X	X	X	B	A	A	A	B	T
M.E.K.	100	A	B	X	X	X	X	X	X	B	A	A	A	A	T
Magnesium Acetate	100	A	A	A	X	X	X	A	I	A	A	A	I	I	T
Magnesium Chloride	150	A	A	A	A	A	A	A	A	A	A	A	A	X	TVBS
Magnesium Hydrate	150	A	A	B	A	B	B	I	I	A	A	A	A	X	T N
Magnesium Hydroxide	150	A	A	B	A	B	B	A	A	A	A	A	A	X	TVBN
Magnesium Sulfate	150	A	A	A	A	A	A	A	B	A	A	A	A	I	TVBNS
Maleic Acid	100	A	X	X	X	I	X	I	I	B	I	A	A	B	TVBNS
Malic Acid	150	B	I	A	A	I	I	I	I	I	I	A	A	B	TVBNS
Manganese Sulfate	150	A	A	A	X	A	A	A	A	A	A	A	A	I	TVBN
Manganese Sulfide	150	A	A	A	X	A	A	A	A	A	A	A	I	I	T V B
Manganese Sulfite	150	A	A	A	X	A	A	A	A	A	A	A	I	I	T V B
Menthanol	100	A	A	A	A	X	A	A	A	A	A	A	A	I	T B
Mesityl Oxide	100	A	B	X	X	X	X	B	X	A	B	A	A	I	T B
Methallyl Alcohol	100	A	A	A	A	B	A	A	A	A	A	A	I	I	T B
Methyl (Wood) Alcohol	100	A	A	A	A	X	A	A	A	A	A	A	A	I	TBNS
Methyl Acetate	100	A	A	B	X	X	X	A	A	A	A	A	A	I	T
Methyl Acetoacetate	100	A	B	X	X	X	X	A	I	A	A	A	I	I	T
Methyl Acetone	---	No Hose Recommended for this Application										A	I		
Methyl Amyl Acetate	100	B	A	B	X	X	X	I	X	A	B	A	I	I	T
Methyl Amyl Alcohol	100	A	A	A	A	B	A	A	A	A	A	A	I	I	T B N
Methyl Amyl Carbinol	100	A	A	A	A	B	A	A	A	A	A	A	I	I	T B
Methyl Amyl Ketone	100	A	B	X	X	X	X	X	I	A	B	A	I	I	T
Methyl Benzene	100	A	X	X	X	A	X	X	X	A	B	A	A	A	T V
Methyl Butanol	100	A	A	A	A	B	A	A	I	A	A	A	A	I	T B N

Temperature 150°F (66°C) and 100°F (38°C).

Polymer Code

A = May be used for continuous service **X** = Do not use
B = May be used for intermittent service **I** = Insufficient data

T = Teflon® **N** = Neoprene
V = Vitron® **S** = Silicone
B = Nitrile

	1	2	3	4	5	6	7	8	9	10	11	Insta-Lock™			
									Blue Flexwing®						
Temp. (F°)	Fabchem™	Gray Flexwing®	Yellow Flexwing®	Tan Flexwing®	Orange Flexwing®	Flexwing® Petroleum	Brown Flexwing®	Purple Flexwing®	Green XLPE	Viper™	HI-PER®	316 SS	Aluminum	Gasket	
H															
Methyl Butanone	100	A	B	X	X	X	X	B	B	A	B	A	I	I	T
Methyl Butyl Ketone	100	A	B	X	X	X	X	X	I	A	B	A	A	B	T
Methyl Carbitol	100	A	A	A	X	I	X	A	I	A	A	A	I	I	T
Methyl Cellosolve	100	A	A	A	X	I	X	A	A	A	A	A	A	B	T
Methyl Chloride	---	No Hose Recommended for this Application										A	X		
Methyl Cyclohexane	100	A	X	X	X	B	X	B	X	B	I	A	I	I	T V
Methyl Ethyl Ketone	100	A	A	A	B	A	A	A	A	A	A	A	I	I	T
Methyl Hexanol	100	A	A	A	B	A	A	A	A	A	A	A	I	I	T V B
Methyl Hexanone	100	A	B	X	X	X	X	X	I	A	B	A	I	I	T
Methyl Hexyl Ketone	100	A	B	X	X	X	X	X	I	A	B	A	I	I	T
Methyl Isobutyl Carbinol	100	A	A	A	A	B	A	A	A	A	A	A	B	I	T B N
Methyl Isobutyl Ketone (MIBK)	100	A	B	X	X	X	X	B	B	A	B	A	A	B	T
Methyl Isopropyl Ketone	100	A	B	X	X	X	X	B	B	A	B	A	A	I	T
Methyl Normal Amyl Ketone	100	A	B	X	X	X	X	I	I	A	B	A	I	I	T
Methyl Propyl Carbinol	100	A	A	A	A	B	A	A	A	A	A	A	I	I	T B
Methyl Propyl Ether	100	A	X	B	X	I	X	I	X	A	B	A	I	I	T
Methyl Propyl Ketone	100	A	B	X	X	X	X	B	I	A	B	A	I	I	T
Methyl Tertiary Butyl Ether (MTBE) (100% Concentrate)	100	X	X	X	X	X	X	X	X	A	B	I	I	I	
Methylallyl Acetate	100	A	A	B	X	X	X	I	A	A	A	A	I	I	T
Methylallyl Chloride	100	A	X	X	X	X	X	X	I	B	I	A	I	I	T
Methyldiethanolamine	100	A	X	X	X	X	A	A	X	A	A	A	I	I	T B
Methylene Bromide	100	B	X	X	X	B	X	I	X	B	A	A	I	I	T V
Methylene Chloride	---	No Hose Recommended for this Application										A	I		
Metribuzin	100	A	I	I	I	I	I	I	A	I	I	A	I	I	T
Mineral Spirits	100	A	X	X	X	B	A	I	X	A	B	A	A	A	T B
Monochloroacetic Acid	100	A	X	X	B	I	X	A	X	A	A	A	A	X	T
Monochlorobenzene	100	B	X	X	X	A	X	X	X	B	B	A	A	B	T V
Monochlorodifluoromethane	100	I	X	X	X	X	X	I	I	I	I	A	A	I	T N
Monoethanol Amine	100	A	A	X	B	I	B	A	B	A	B	A	A	B	T N
Monoethyl Amine	---	No Hose Recommended for this Application										A	B		
Monoisopropanol Amine	100	A	A	X	B	I	B	I	I	A	B	A	I	I	T B
Muriatic Acid	125	A	X	X	A	I	X	A	X	A	A	A	X	X	T
N															
N/Methylpyrrolidone	100	A	X	X	X	X	X	X	X	A	I	A	I	I	T
Naphtha	100	A	X	X	X	A	A	A	X	A	A	A	A	A	T V B N
Naphthalene	100	A	X	X	X	A	X	I	X	A	I	A	A	B	T V
Natural Gas	---	No Hose Recommended for this Application										A	A		
Neohexane	100	A	X	X	X	A	A	B	X	A	B	A	A	A	T V B
Neu-Tri	100	A	X	X	X	A	X	I	X	A	B	A	I	I	T V
Nickel Chloride	150	A	A	A	A	A	A	A	A	A	A	A	B	X	T V B S
Nickel Nitrate	150	A	A	A	A	A	A	A	A	A	A	A	B	X	T V B N

Temperature 150°F (66°C), 100°F (38°C) and 125°F (52°C).

Polymer Code

A = May be used for continuous service **X** = Do not use
B = May be used for intermittent service **I** = Insufficient data

T = Teflon® **N** = Neoprene
V = Vitron® **S** = Silicone
B = Nitrile

	1	2	3	4	5	6	7	8	9	10	11	Insta-Lock™			
									Blue Flexwing®						
Temp. (F°)	Fabchem™	Gray Flexwing®	Yellow Flexwing®	Tan Flexwing®	Orange Flexwing®	Flexwing® Petroleum	Brown Flexwing®	Purple Flexwing®	Green XLPE	Viper™	HI-PER®	316 SS	Aluminum	Gasket	
N															
Nickel Sulfate	150	A	A	A	A	A	A	A	A	A	A	A	X	TVBNS	
Nitric Acid (25%)	100	B	B	X	X	X	X	X	B	A	A	A	X	TV	
Nitric Acid (37%)	100	X	X	X	X	X	X	X	X	A	A	A	X	TV	
Nitric Acid (40% - 60%)	100	X	X	X	X	X	X	X	X	B	A	A	X	TV	
Nitric Acid (70%)	100	X	X	X	X	X	X	X	X	B	A	B	X	T	
Nitro Benzene	100	A	X	X	X	B	X	X	A	B	A	A	B	T	
Nitrogen Gas	100	A	A	A	A	A	A	A	A	A	A	A	I	TVBNS	
Nitrous Oxide	100	A	A	A	A	A	A	A	A	A	A	A	I	TVBNS	
Nonenes	100	A	X	X	X	A	A	I	X	A	B	A	I	TVB	
O															
Octadecanoic Acid	100	A	B	X	X	I	A	A	B	A	A	A	B	TB	
Octane	100	B	X	X	X	A	A	A	X	B	B	A	B	TVB	
Octanol	100	A	A	A	A	B	A	A	X	A	A	A	I	TBN	
Octyl Acetate	100	A	A	A	X	X	X	I	A	B	A	I	I	T	
Octyl Alcohol	100	A	A	A	A	B	A	A	X	A	A	A	T	TB	
Octyl Aldehyde	100	A	X	X	X	X	I	I	A	I	A	I	I	T	
Octyl Amine	100	A	B	X	X	X	B	I	A	B	A	I	I	T	
Octyl Carbinol	100	A	A	A	A	B	A	A	A	A	A	I	I	TB	
Octylene Glycol	100	A	A	A	A	A	A	A	A	A	A	I	I	TVB	
Oil Petroleum	100	B	X	X	X	A	A	A	X	A	B	A	A	TVB	
Oleic Acid	100	A	B	X	X	I	A	A	X	A	B	A	A	TB	
Oleum	100	X	X	X	X	X	X	X	X	X	A	I	X	TV	
Organic Fatty Acids	100	A	X	X	X	X	A	A	X	A	B	A	A	TB	
Orthodichlorobenzene	100	A	X	X	X	A	X	I	X	A	B	A	I	TV	
Orthodichlorobenzol	100	A	X	X	X	A	X	I	X	A	I	A	I	TV	
Orthoxylene	100	B	X	X	X	A	X	I	X	A	B	A	I	TV	
Oxalic Acid	100	A	A	X	X	I	X	A	B	I	B	A	A	TS	
Oxygen	---	No Hose Recommended for this Application										A	A		
Ozone	100	A	B	B	X	I	X	A	A	I	B	A	I	TS	
P															
Palmitic Acid	100	A	A	B	X	I	A	A	B	B	B	A	A	TBS	
Papermakers Alum	150	A	A	A	A	A	A	A	A	A	A	A	I	TVBN	
Paradichlorobenzol	100	B	X	X	X	A	X	I	X	A	I	A	I	TV	
Paraffin	150	A	B	X	X	A	A	A	X	X	I	A	A	TVB	
Paraldehyde	100	A	B	X	X	X	X	I	B	A	B	A	A	T	
Paraxylene	100	A	X	X	X	A	X	I	X	A	B	A	I	TV	
Pelargonic Acid	100	A	A	X	X	I	A	I	I	A	I	A	I	TB	
Pentachloroethane	100	A	X	X	X	A	X	I	X	A	I	A	A	TV	
Pentane	100	X	X	X	X	A	A	A	X	B	X	A	B	TVB	
Pentanol	100	A	A	A	A	B	A	A	A	A	A	A	I	TBN	
Pentanone	100	A	B	X	X	X	X	B	I	A	B	A	I	T	
Perchloroethylene	100	B	X	X	X	A	X	X	X	A	B	A	A	TV	

Temperature 150°F (66°C) and 100°F (38°C).

Polymer Code

A = May be used for continuous service **X** = Do not use
B = May be used for intermittent service **I** = Insufficient data

T = Teflon® **N** = Neoprene
V = Vitron® **S** = Silicone
B = Nitrile

	1	2	3	4	5	6	7	8	9	10	11	Insta-Lock™			
									Blue Flexwing®						
Temp. (F°)	Fabchem™	Gray Flexwing®	Yellow Flexwing®	Tan Flexwing®	Orange Flexwing®	Flexwing® Petroleum	Brown Flexwing®	Purple Flexwing®	Green XLPE	Viper™	HI-PER®	316 SS	Aluminum	Gasket	
P															
Petroleum Ether (Ligroin)	100	A	X	X	X	A	A	A	X	A	B	A	A	A	T V B
Petroleum - Crude	100	A	X	X	X	A	A	A	X	A	B	A	A	A	T V B
Petroleum Oils	100	A	X	X	X	A	A	A	X	A	B	A	A	A	T V B
Phenol	125	A	A	X	X	A	X	A	X	A	B	A	A	B	T V
Phenolsulfonic Acid	100	X	X	X	X	X	X	A	I	B	B	A	B	I	T
Phenyl Chloride	100	A	X	X	X	A	X	X	X	A	B	A	A	B	T V
Phosphoric Acid (10%)	150	A	A	A	A	X	A	A	A	A	A	A	A	X	TVBN
Phosphoric Acid (10% - 85%)	100	A	A	A	B	X	X	A	A	A	A	A	A	X	T V N
Pine Oil	100	A	X	X	X	A	X	B	X	A	B	A	A	I	T V
Pinene	100	A	X	X	X	A	B	B	X	A	B	A	B	I	T V
Polyethylene Glycol	150	A	A	A	A	A	A	A	A	A	A	A	I	I	TVBN
Polypropylene Glycol	150	A	A	A	A	A	A	A	A	A	A	A	I	I	T V B
Potassium Acetate	100	A	A	B	X	X	X	A	B	A	A	A	A	X	T B
Potassium Bisulfate	150	A	A	A	A	A	A	A	A	A	A	A	A	I	TVBN
Potassium Bisulfite	150	A	A	A	A	A	A	A	A	A	A	A	I	I	TVBN
Potassium Carbonate	150	A	A	A	A	A	A	A	A	A	A	A	A	X	TVBNS
Potassium Chloride	150	A	A	A	A	A	A	A	A	A	A	A	A	X	TVBNS
Potassium Chromate	150	B	A	X	I	I	I	A	I	B	B	A	B	I	TVBN
Potassium Dichromate	150	B	A	X	I	I	I	A	I	B	B	A	A	B	TVBNS
Potassium Hydrate	150	A	A	B	A	X	B	A	B	A	A	A	A	X	T S
Potassium Hydroxide	150	B	A	B	A	X	B	A	B	A	A	A	A	X	T N
Potassium Nitrate	150	A	A	A	A	A	A	A	A	A	A	A	A	B	TVBNS
Potassium Permanganate	100	A	A	A	A	A	B	I	I	A	A	A	A	I	T V S
Potassium Silicate	150	A	A	A	A	A	A	A	A	A	A	A	A	I	TVBNS
Potassium Sulfate	150	A	A	A	A	A	A	A	A	A	A	A	A	B	TVBNS
Potassium Sulfide	150	A	A	A	A	A	A	A	A	A	A	A	A	X	TVBNS
Potassium Sulfite	150	A	A	A	A	A	A	A	A	A	A	A	A	I	TVBNS
Propanediol	100	A	A	A	A	A	A	A	A	A	A	A	I	I	TVBS
Propane Gas	---	No Hose Recommended for this Application													
Propanol	100	A	A	A	A	B	A	A	A	A	A	A	A	I	T V B
Propyl Acetate	100	A	A	B	X	X	X	B	X	A	B	A	A	I	T
Propyl Alcohol	100	A	A	A	A	B	A	A	A	A	A	A	A	I	T B
Propyl Aldehyde	100	A	B	X	X	X	X	X	I	A	B	A	I	I	T
Propyl Chloride	---	No Hose Recommended for this Application													
Propylene Diamine	100	A	A	X	B	I	B	A	I	A	I	A	I	I	T B
Propylene Dichloride	100	B	X	X	X	B	X	X	X	B	I	A	A	X	T V
Propylene Glycol	100	A	A	A	A	A	A	A	A	A	A	A	A	I	TVBS
Propylene Tetramer	100	A	X	X	X	X	A	A	X	A	B	I	I	I	B
S															
Sea Water	100	A	A	A	A	A	A	A	A	A	A	A	A	I	TVBNS
Sewage	100	A	X	A	X	I	A	A	A	A	A	A	A	X	TVBNS
Silicate of Soda	100	AA	A	A	A	A	A	A	A	A	A	A	A	X	TVBNS

Temperature 150°F (66°C) and 100°F (38°C).

Polymer Code

A = May be used for continuous service **X** = Do not use
B = May be used for intermittent service **I** = Insufficient data

T = Teflon® **N** = Neoprene
V = Vitron® **S** = Silicone
B = Nitrile

	1	2	3	4	5	6	7	8	9	10	11	Insta-Lock™			
									Blue Flexwing®						
	Temp. (F°)	Fabchem™	Gray Flexwing®	Yellow Flexwing®	Tan Flexwing®	Orange Flexwing®	Flexwing® Petroleum	Brown Flexwing®	Purple Flexwing®	Green XLPE	Viper™	HI-PER®	316 SS	Aluminum	Gasket
S															
Soap	100	A	X	X	X	X	A	A	X	X	I	A	A	X	TBNS
Soda Ash	100	A	A	A	A	A	A	A	A	A	A	A	A	X	TVBNS
Soda, Caustic	100	A	A	B	A	X	B	A	A	A	A	A	A	X	T N S
Soda, Lime	100	A	A	B	A	X	B	A	A	A	A	A	I	I	T V B
Soda, Niter	100	A	A	A	A	A	A	A	B	A	A	A	A	B	T V B
Sodium Acetate	100	A	A	A	X	X	X	A	B	B	B	A	A	I	T N S
Sodium Aluminate	100	A	A	A	A	A	A	A	A	A	A	A	A	I	TVBN
Sodium Bisulfate	150	A	A	A	A	A	A	A	A	A	A	A	A	X	TVBNS
Sodium Bisulfite	150	A	A	A	A	A	A	A	A	A	A	A	A	X	TVBNS
Sodium Carbonate	150	A	A	A	A	A	A	A	A	A	A	A	A	X	TVBNS
Sodium Chloride (Brine)	150	A	A	A	A	A	A	A	A	A	A	A	A	X	TVBNS
Sodium Chromate	150	X	A	X	I	I	I	A	I	X	I	A	A	A	TVBN
Sodium Dichromate	150	A	A	X	I	I	I	A	A	A	A	A	A	I	T
Sodium Hydrate	150	A	A	B	A	X	B	A	A	A	A	A	B	X	T N
Sodium Hydrochlorite (20%)	100	A	B	X	X	B	X	I	I	B	A	A	I	I	T
Sodium Hydrosulfide	100	A	X	X	X	X	A	A	X	A	I	A	I	B	T B
Sodium Hydroxide (50%)	150	A	A	B	A	X	B	A	A	A	A	A	A	X	T B N
Sodium Hypochlorite	100	B	B	X	X	B	X	A	A	X	B	A	X	X	T V S
Sodium Nitrate	150	A	A	A	A	A	A	A	B	A	A	A	A	B	TVBNS
Sodium Silicate	150	A	A	A	A	A	A	A	A	A	A	A	A	X	TVBNS
Sodium Sulfate	150	A	A	A	A	A	A	A	A	A	A	A	A	B	TVBNS
Sodium Sulfide	150	A	A	A	A	A	A	A	A	A	A	A	A	X	TVBN
Sodium Sulfite	150	A	A	A	A	A	A	A	B	A	A	A	A	I	TVBNS
Sodium Sulphhydrate	100	A	X	X	X	X	A	A	X	A	B	A	I	I	T B
Sodium Thiosulfate	150	A	A	A	A	A	A	A	A	A	A	A	A	I	TVBNS
Stannic Chloride	150	A	A	A	A	I	A	A	A	A	A	A	X	X	T B
Stannic Sulfide	150	A	A	A	A	I	A	A	A	A	A	A	I	I	T B N
Stannous Chloride	150	A	A	A	A	I	A	A	B	A	A	A	A	X	T B
Stannous Sulfide	150	A	A	A	A	I	A	A	A	A	A	A	I	I	T B
Stearic Acid	100	A	B	X	X	I	A	A	B	A	A	A	A	B	T V B
Stoddards Solvent	100	A	X	X	X	A	A	A	X	A	B	A	A	A	T V B
Styrene	100	B	X	X	X	A	X	X	X	X	I	A	A	I	T V
Sulfamic Acid (>10%)	100	X	A	B	B	I	B	A	I	I	I	A	I	I	T V N
Sulfonic Acid	100	B	X	X	X	X	X	I	I	B	I	A	I	I	T V N
Sulfur Dioxide (Liquid)	100	B	B	B	I	X	I	I	I	X	I	A	A	I	T N
Sulfuric Acid (25%)	150	A	A	B	B	I	X	A	A	A	A	A	I	X	T V N
Sulfuric Acid (93%)	100	X	A	B	X	B	X	A	B	A	A	A	I	X	T V
Sulfuric Acid (93%-98%)	100	X	X	X	X	B	X	X	X	I	B	A	I	X	T V
Sulfuric Acid Fuming	100	X	X	X	X	X	X	X	X	X	X	A	I	X	T
Sulfurous Acid (10%)	150	A	A	A	A	I	X	A	A	A	A	A	I	X	T
Sulfurous Acid (10%-75%)	100	A	A	A	A	I	X	A	A	A	A	A	I	X	T
Sulphonate	100	I	X	X	X	X	A	A	X	X	I	I	I	I	B

Temperature 150°F (66°C) and 100°F (38°C).

Polymer Code

A = May be used for continuous service **X** = Do not use
B = May be used for intermittent service **I** = Insufficient data

T = Teflon® **N** = Neoprene
V = Vitron® **S** = Silicone
B = Nitrile

	1	2	3	4	5	6	7	8	9	10	11	Insta-Lock™			
									Blue Flexwing®						
Temp. (F°)	Fabchem™	Gray Flexwing®	Yellow Flexwing®	Tan Flexwing®	Orange Flexwing®	Flexwing® Petroleum	Brown Flexwing®	Purple Flexwing®	Green XLPE	Viper™	HI-PER®	316 SS	Aluminum	Gasket	
T															
Tall Oil	100	A	X	X	X	A	A	I	X	I	I	A	A	X	T V B
Tallow	150	A	X	X	X	I	A	A	X	I	I	A	A	I	TBNS
Tannic Acid	150	A	A	A	A	I	B	A	X	I	I	A	A	X	TVBN
Tar	---	Special Hose Required											A	A	
Tartaric Acid	150	A	A	A	A	I	A	A	A	A	A	A	A	I	T B N
Tergitol	100	X	I	I	I	I	I	I	I	I	I	A	I	I	T
Tertiary Butyl Alcohol	100	A	A	A	A	B	A	A	A	A	A	A	I	I	T B
Tetrachlorobenzene	100	B	X	X	X	B	X	I	X	B	I	A	I	I	T
Tetrachloroethane	100	A	X	X	X	A	X	I	X	X	I	A	A	X	T V
Tetrachloroethylene	100	A	X	X	X	A	X	X	X	A	B	A	A	B	T V
Tetrachloromethane	100	A	X	X	X	A	X	X	X	X	B	A	A	I	T V
Tetrachloronaphthalene	100	B	X	X	X	B	X	I	X	X	I	A	I	I	T
Tetradecanol	100	A	A	A	A	B	A	A	A	A	A	A	I	I	T B
Tetraethylene Glycol	150	A	A	A	A	A	A	A	A	A	A	A	I	I	T V B
Tetraethylene Lead	100	X	X	X	X	A	X	X	X	X	I	A	I	I	T V
Tetrahydrofuran	100	B	X	X	X	X	X	X	X	B	X	A	A	B	T
THF	100	B	X	X	X	X	X	X	X	B	X	A	A	B	T
Thionyl Chloride	100	X	I	I	I	I	I	I	I	I	X	A	X	X	T
Tin Chloride	100	A	A	A	A	I	A	A	A	A	A	A	X	X	T V B
Tin Tetrachloride	150	B	A	A	A	I	A	A	A	A	A	A	X	X	T B
Toluene	100	A	X	X	X	A	X	X	X	B	B	A	A	A	T V
Toluidine	100	X	I	I	I	I	I	I	I	I	I	A	I	I	T
Toluol	100	A	X	X	X	A	X	X	X	A	B	A	A	A	T V
Transformer Oil	100	X	I	I	I	I	I	I	I	I	I	A	A	I	T
Transmission Oil "A"	150	B	X	X	X	A	A	I	X	I	I	A	A	A	T V B
Tributoxy Ethylsulphate	100	I	A	X	X	A	X	X	A	X	I	I	I	I	V
Tributyl Amine	100	A	A	X	B	I	B	A	I	A	A	A	I	I	T
Tributyl Phosphate	100	A	A	X	X	X	X	X	X	A	I	A	A	I	T
Trichlorobenzene	100	B	X	X	X	B	X	X	X	B	I	A	I	A	T
Trichloroethane	100	A	X	X	X	A	X	B	X	X	B	A	A	I	T V
Trichloroethylene	100	X	X	X	X	A	X	X	X	X	B	A	A	I	T V
Trichloropropane	100	A	X	X	X	A	X	I	X	A	I	A	A	X	T V
Tricresylphosphate	100	A	A	X	X	A	X	A	A	A	I	A	A	X	T V
Tridecanol	100	A	A	A	A	B	A	A	A	A	A	A	I	I	T B
Triethanolamine	100	A	A	X	B	X	B	A	A	A	A	A	A	I	T B
Triethylamine	100	A	A	X	B	I	B	A	I	A	A	A	A	I	TVBN
Triethylene Glycol	150	A	A	A	A	I	A	A	I	A	A	A	A	A	T B
Trifuralin (Trefalin)	100	A	X	X	X	A	X	X	X	A	I	A	I	I	T V
Triphenyl Phosphate	100	A	A	X	X	I	X	I	I	A	I	A	A	I	T
Tripolyphosphate	100	X	I	I	I	I	I	I	I	I	I	A	I	I	T

Temperature 150°F (66°C) and 100°F (38°C).

Polymer Code

A = May be used for continuous service **X** = Do not use
B = May be used for intermittent service **I** = Insufficient data

T = Teflon® **N** = Neoprene
V = Vitron® **S** = Silicone
B = Nitrile

	1	2	3	4	5	6	7	8	9	10	11	Insta-Lock™			
									Blue Flexwing®						
	Temp. (F°)	Fabchem™	Gray Flexwing®	Yellow Flexwing®	Tan Flexwing®	Orange Flexwing®	Flexwing® Petroleum	Brown Flexwing®	Purple Flexwing®	Green XLPE	Viper™	HI-PER®	316 SS	Aluminum	Gasket
T															
Trisodium Phosphate	150	A	A	A	A	A	A	A	A	A	A	A	A	X	TVBNS
Turpentine	100	A	X	X	X	A	A	B	X	A	X	A	A	A	T V B
U															
Urea	100	A	A	I	I	I	X	A	I	A	A	A	A	B	TVBN
Undecanol	100	B	A	A	A	B	A	A	A	A	A	A	I	I	T B
V															
V.M. & P. Naptha	100	A	X	X	X	A	A	I	X	A	I	A	I	I	TVBS
Vinyl Acetate	100	A	A	B	X	X	X	A	X	A	B	A	A	I	T V
Vinyl Benzene	100	A	X	X	X	A	X	X	X	A	I	A	A	I	T V
Vinyl Chloride	---	No Hose Recommended for this Application													
Vinyl Ether	---	No Hose Recommended for this Application													
Vinyl Toluene	100	A	X	X	X	A	X	X	X	A	I	A	I	I	T V
Vinyl Trichloride	100	A	X	X	X	A	X	X	X	A	B	A	A	I	T V
W															
Water	180	A	A	A	A	A	A	A	A	A	A	A	A	I	TVBNS
Wax	100	A	X	X	X	X	A	A	X	X	X	A	A	I	TVBN
White Oil	100	A	X	X	X	I	A	A	X	I	I	A	I	I	T V B
Wood Alcohol	100	A	A	A	A	X	A	A	A	A	A	A	A	I	TBNS
X															
Xylene (Xylol)	100	X	X	X	X	A	X	X	X	A	B	A	A	I	T V
Xylidine	100	B	X	X	X	X	X	X	X	B	B	A	B	A	T
Z															
Zinc Carbonate	150	A	A	A	A	A	A	A	A	A	A	A	B	B	TVBN
Zinc Chloride	150	A	A	A	A	A	A	A	A	A	A	A	A	X	TVBNS
Zinc Chromate	150	A	A	X	I	I	I	A	X	B	I	A	I	I	T
Zinc Phosphate	100	A	X	X	X	X	A	A	A	X	I	A	I	I	TBNS
Zinc Sulfate	150	A	A	A	A	A	A	A	A	A	A	A	A	X	TVBNS

Temperature 150°F (66°C), 100°F (38°C) and 180°F (82°C).

ContiTech



Contact

ContiTech AG
NAFTA Headquarters
703 S. Cleveland Massillon Road
Fairlawn, OH 44333-3023 U.S.A.
1-800-235-4632

Canada

1-888-275-4397
FAX 1-888-464-4397

Mexico

1-800-439-7373
FAX 1-800-062-0918

Germany

+49 (0)511 938 02
mailservice@contitech.de

www.contitech.us

ContiTech. Engineering Next Level

As a division of the Continental Group, ContiTech is a recognized innovation and technology leader in natural rubber and plastics. As an industry partner with a firm future ahead of us, we engineer solutions both with and for our customers around the world. Our bespoke solutions are specially tailored to meet the needs of the market. With extensive expertise in materials and processes, we are able to develop cutting-edge technologies while ensuring we make responsible use of resources. We are quick to respond to important technological trends, such as function integration, lightweight engineering and the reduction of complexity, and offer a range of relevant products and services. That way, when you need us, you'll find we're already there.